



Ene 2025

Catálogo de productos 2025





PREFABRICADOS
Duero

CATÁLOGO

2025

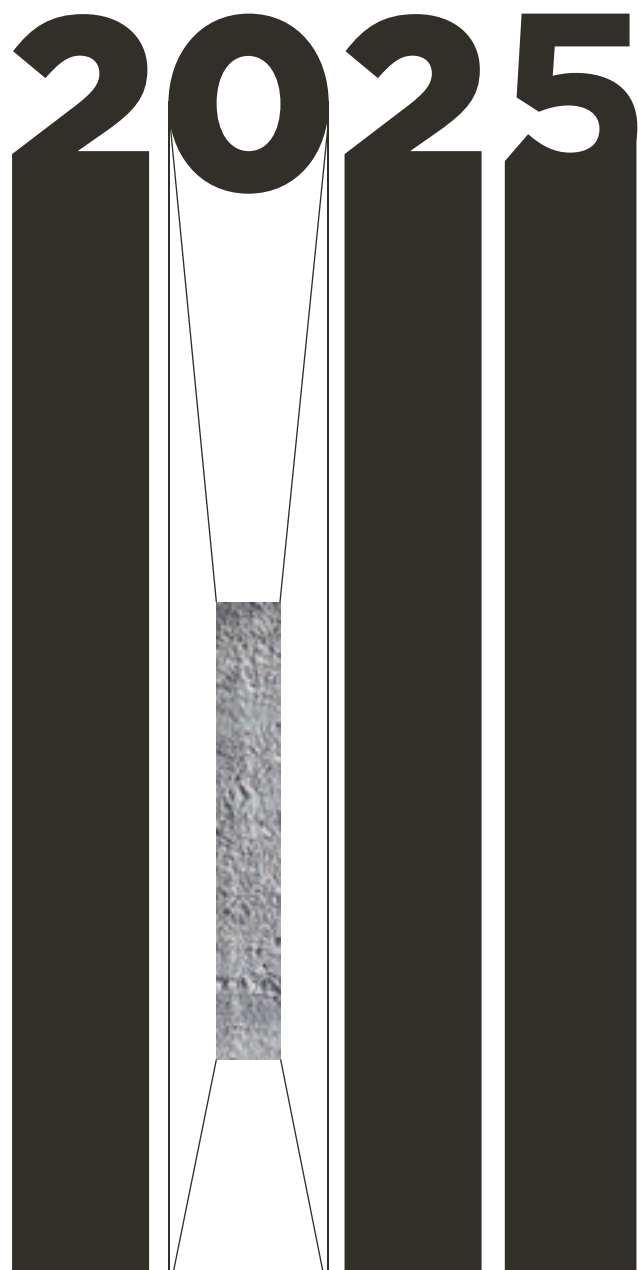

JOSÉ ISIDRO TORRES

OBRA CIVIL
FORJADOS
BLOQUES



50 años

Historia

Instalaciones

Calidad



Bordillos

Adoquines y baldosas

Baldosa hidráulica

Bloques

Bovedillas y casetones

Arquetas

Tubos

Marcos de hormigón

Forjados y ferrallas

Árido ensacado

Áridos



Hormigones

Transporte y maquinaria



Materiales ecológicos

Procesos sostenibles



The logo for 50 years, featuring the number '50' in a bold, black font. The zero is stylized with a white arrow pointing to the right, and the entire logo is set against a white background.

50 años

A horizontal red bar with a white arrow pointing to the right, containing the text 'al servicio de la construcción'.

al servicio de la construcción

JIT es en la actualidad una empresa **referente en Castilla y León** alcanzando también a otras comunidades en su proyección comercial.

La filosofía de **calidad y progresión tecnológica** se combina con el carácter humano y trabajador de sus profesionales, generando una alta efectividad en el conjunto de productos y actividades que desarrolla.

Así, JIT proporciona **servicios completos de estudio, fabricación y logística** de cara al cliente desde los movimientos de tierra y alquiler de maquinaria con conductor, transportes especiales (góndolas y cisternas), producción de hormigón, extracción y machaqueo de áridos y la producción de prefabricados de hormigón, ferralla elaborada, diseño y cálculo de estructuras.



Nuestra historia

José Isidro Torres (JIT) inició sus actividades en el mundo del transporte y la construcción en los años setenta, para constituirse como sociedad en 1991.

En el año 1991 nace **José Isidro Torres S.L.**, en 1993 **Hormigones Duero S.L.** y en 2004, con el firme propósito de ampliar las actividades y dar un mayor servicio a nuestros clientes nace un nuevo proyecto, bajo el nombre comercial de **Prefabricados Duero**, culminado con la instalación de una línea de fabricación de tubos de hormigón armado y masa.

Como continuación a esta evolución, en el año 2005 se crea un laboratorio en nuestras instalaciones para el **autocontrol de áridos, hormigones y prefabricados de hormigón.**

En todo este tiempo, hemos logrado desarrollar nuevas gamas de productos, como **ECOLife**, capaces de interrelacionar con la naturaleza y permitir ampliar nuestra oferta con pavimentos mas ecológicos y sostenibles.

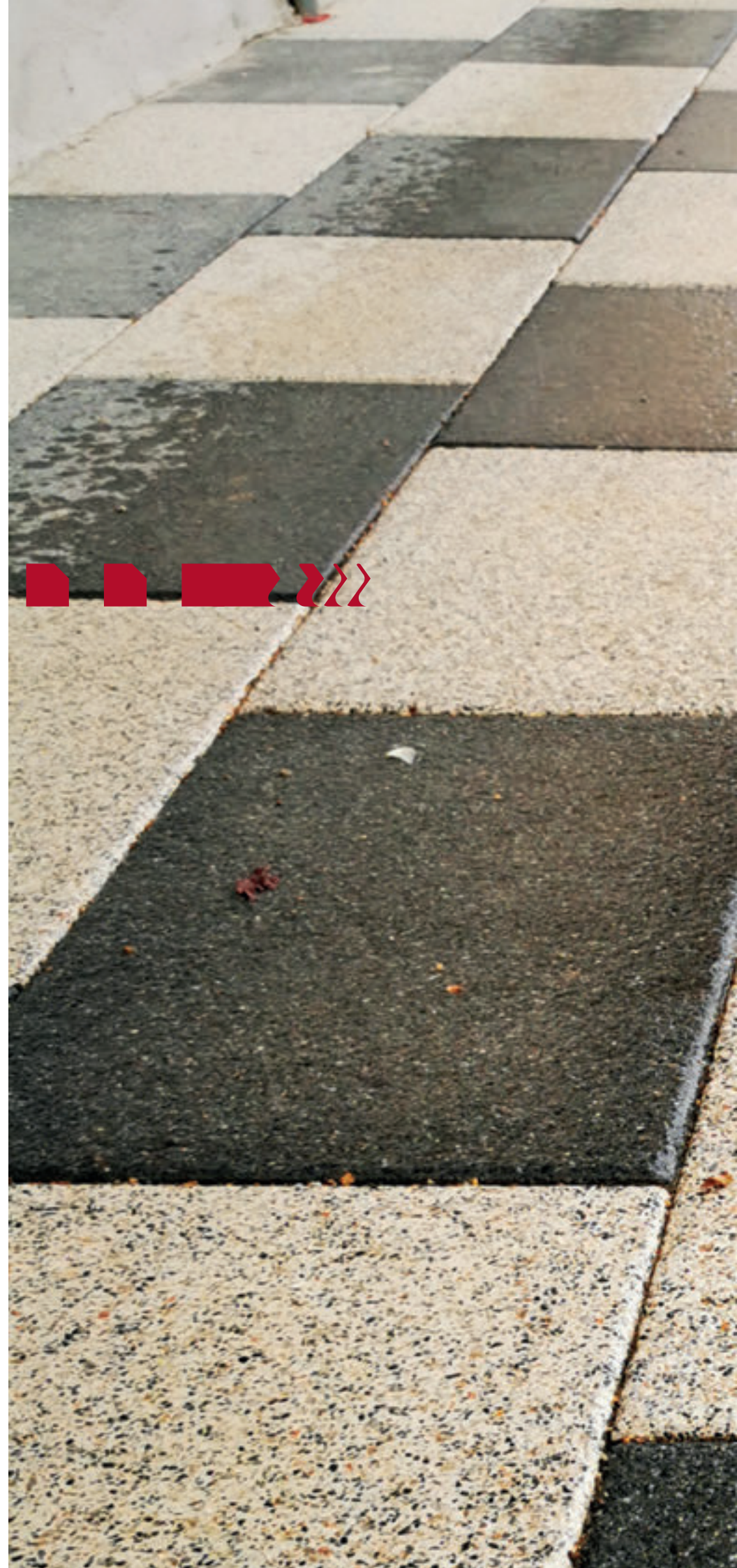





Nuestras instalaciones

- **Toro – Zamora | Ctra. Pozoantiguo Km. 1,1**
Fábricas de prefabricados de hormigón, fábrica de viguetas y prelosas, fábrica de tubos y arquetas y fábrica de ferralla.
- **Toro – Zamora | Ctra. Toro-Salamanca Km. 2,5**
Planta de selección y lavado de áridos, planta de grava cemento y planta de hormigón.
- **Toro – Zamora | Ctra. Toro-Alaejos Km 7**
Planta de selección y lavado de áridos, planta de machaqueo de áridos, planta de machaqueo de zahorras y planta de machaqueo de bolos.
- **Villardefrades – Valladolid | Ctra. Medina de Rioseco- Toro Km. 24,7**
Planta de hormigón
- **Tordesillas – Valladolid | N-122 Km 398**
Planta de hormigón
- **Coreses – Zamora | Ctra. Tordesillas Km 9. Sitio de las Cañadas S/N**
Planta de hormigón









Calidad garantizada

JIT es sinónimo de calidad, ya que posee el registro de empresa **ER (1492/2003)** y el **certificado de Gestión Ambiental (GA 2003 / 0403)** concedidos por AENOR, además del marcado CE de áridos, zahorras, viguetas armadas, prelosas armadas y bovedillas de hormigón (todos ellos englobados en el sistema 2+)

Además, dispone de declaraciones de prestaciones para todos sus productos (los regidos por el sistema 4 del mercado).

Nuestro laboratorio de autocontrol dispone del personal técnico muy cualificado y de los materiales más adecuados para optimizar los controles de calidad de nuestros productos, optimizando así los procesos que se realizan durante la fabricación.



Bordillos

Global **EPD**

A VERIFIED ENVIRONMENTAL DECLARATION

Bordillos

DUERO MONOCAPA

50x25x10x8	17
50x20x8 Semicurvo	18
50x20x8 Curvo	19
50x20x10 Recto	21
50x20x10 Curvo	22
Pecho Paloma 30x27x9	24
Soria 30x29x13	25
Ondas 50x20x6	26

DUERO BICAPA

100x20x8 Recto	29
100x20x8 Redondo	30
100x20x10 Recto	31
100x20x10x9	32
100x20x14x11	34
100x25x12x9	35
100x25x15x12	36
100x28x15x12	37
100x28x17x14	38
50x25x15x12	40
KAZ 100x30x13x10	41
KAZ 50x30x13x10	42
Isleta 100x22x20x4	43
Isleta 50x25x14x7,5	44



Bordillos Duero

MONOCAPA

Los bordillos monocapa son una solución resistente, duradera y versátil para la creación de bordes y delimitación de áreas en la construcción de pavimentos, jardines y espacios urbanos. Su variedad de diseños y colores, su resistencia y facilidad de instalación hacen de ellos una excelente opción para cualquier proyecto de construcción.

Bordillo Duero **MONOCAPA**

50x25x10x8

Especificaciones técnicas.

Fabricados conforme a la norma **UNE-EN 1340**.

Ud./Pallet	42 Uds.
Peso Aprox Ud.	25 Kg.
Peso Aprox. Pallet	1.080 Kg.
Uso	Obra Civil
Textura	Lisa

*Los pesos y medidas son valores orientativos.



Medidas

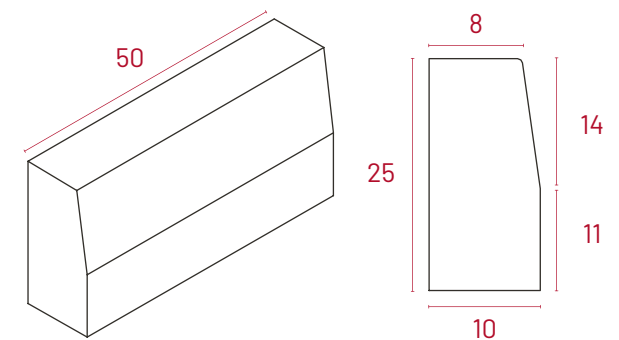

Colores disponibles



Gris

Propiedades del producto



Hidrofugado



Sostenible



Bordillo Duero **MONOCAPA**

50x20x8 Semicurvo

Especificaciones técnicas.

Fabricados conforme a la norma **UNE-EN 1340**.

Ud./Pallet	96 Uds.
Peso Aprox Ud.	18 Kg.
Peso Aprox. Pallet	1.690 Kg.
Uso	Obra Civil
Textura	Lisa

*Los pesos y medidas son valores orientativos.



Medidas

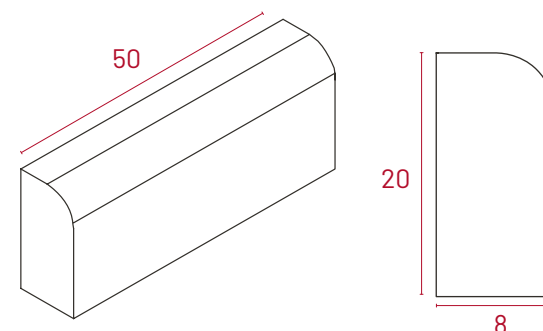

Colores disponibles



Gris Crema Tostado Blanco

Propiedades del producto



Hidrofugado



Sostenible

Bordillo Duero **MONOCAPA**

50x20x8 Curvo

Especificaciones técnicas.

Fabricados conforme a la norma **UNE-EN 1340**.

Ud./Pallet	96 Uds.
Peso Aprox Ud.	18 Kg.
Peso Aprox. Pallet	1.690 Kg.
Uso	Obra Civil
Textura	Lisa

*Los pesos y medidas son valores orientativos.



Medidas

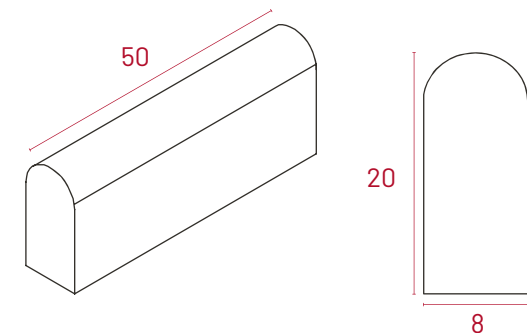

Colores disponibles

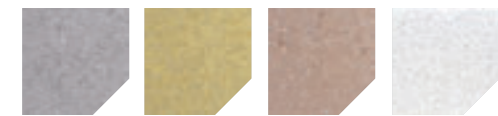

Gris Crema Tostado Blanco

Propiedades del producto



Hidrofugado



Sostenible



Bordillo Duero **MONOCAPA**

50x20x10 Recto

Especificaciones técnicas.

Fabricados conforme a la norma **UNE-EN 1340**.

Ud./Pallet	80 Uds.
Peso Aprox Ud.	21 Kg.
Peso Aprox. Pallet	1.700 Kg.
Uso	Obra Civil
Textura	Lisa

*Los pesos y medidas son valores orientativos.



Medidas

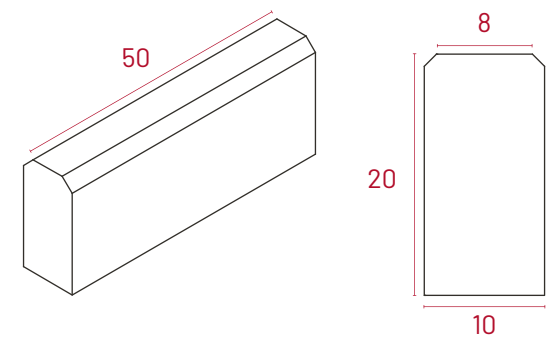

Colores disponibles

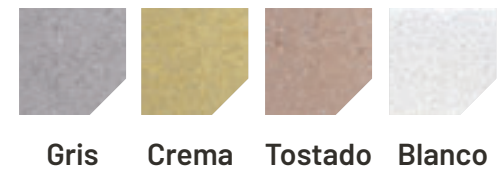

Propiedades del producto



Hidrofugado



Sostenible



Bordillo Duero **MONOCAPA**

50x20x10 **Curvo**

Especificaciones técnicas.

Fabricados conforme a la norma **UNE-EN 1340**.

Ud./Pallet	80 Uds.
Peso Aprox Ud.	21 Kg.
Peso Aprox. Pallet	1.700 Kg.
Uso	Obra Civil
Textura	Lisa

*Los pesos y medidas son valores orientativos.



Medidas

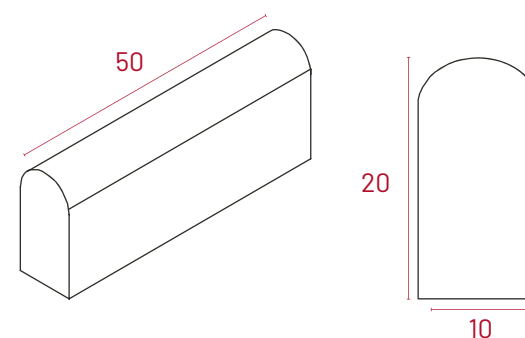

Colores disponibles

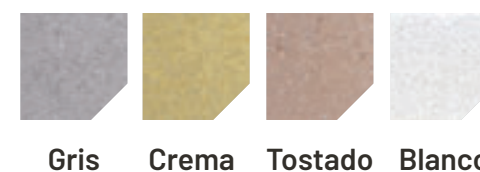

Propiedades del producto



Hidrofugado



Sostenible





Bordillo Duero **MONOCAPA**

Pecho Paloma **30x27x9**

Especificaciones técnicas.

Fabricados conforme a la norma **UNE-EN 1340**.

Ud./Pallet	90 Uds.
Peso Aprox Ud.	14 Kg.
Peso Aprox. Pallet	1.280 Kg.
Uso	Obra Civil
Textura	Lisa

*Los pesos y medidas son valores orientativos.



Medidas

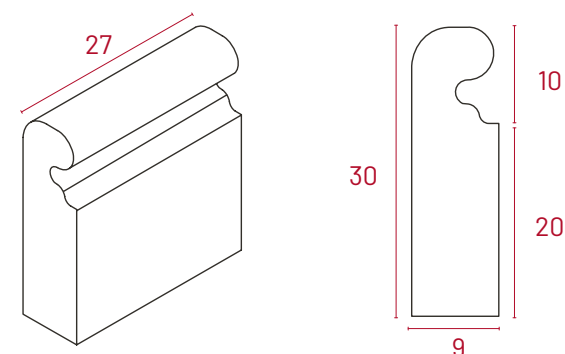

Colores disponibles

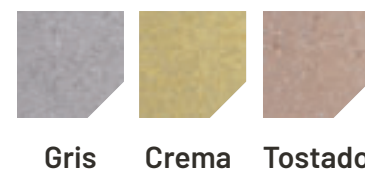

Propiedades del producto



Hidrofugado



Sostenible

Bordillo Duero **MONOCAPA**

Soria **30x29x13**

Especificaciones técnicas.

Fabricados conforme a la norma **UNE-EN 1340**.

Ud./Pallet	63 Uds.
Peso Aprox Ud.	22 Kg.
Peso Aprox. Pallet	1.380 Kg.
Uso	Obra Civil
Textura	Lisa

*Los pesos y medidas son valores orientativos.



Medidas

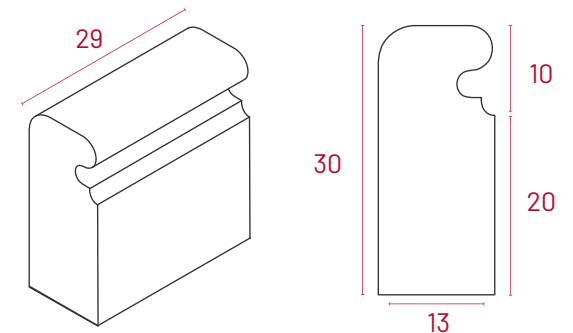

Colores disponibles



Gris Crema Tostado

Propiedades del producto



Hidrofugado



Sostenible



Bordillo Duero **MONOCAPA**

Ondas **50x20x6**

Especificaciones técnicas.

Fabricados conforme a la norma **UNE-EN 1340**.

Ud./Pallet	112 Uds.
Peso Aprox Ud.	14 Kg.
Peso Aprox. Pallet	1.590 Kg.
Uso	Obra Civil
Textura	Lisa

*Los pesos y medidas son valores orientativos.



Medidas

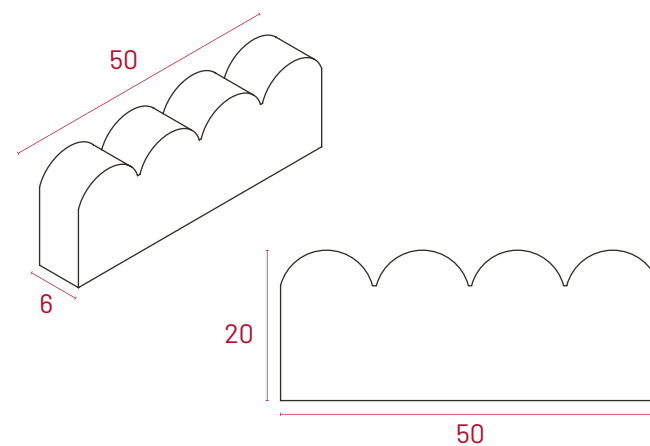

Colores disponibles

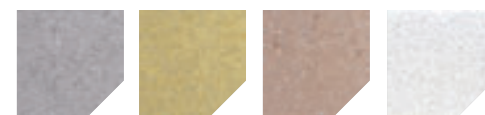

Gris Crema Tostado Blanco

Propiedades del producto



Hidrofugado



Sostenible





Bordillos Duero

DOBLE CAPA

Nuestros bordillos bicapa están disponibles en una amplia gama de tamaños y acabados, lo que los hace ideales para todo tipo de proyectos. Desde pequeñas obras de paisajismo hasta grandes proyectos de infraestructura, nuestros bordillos son una opción excelente para cualquier aplicación.

Bordillo Duero DOBLE CAPA

100x20x8 Recto

Especificaciones técnicas.

Fabricados conforme a la norma **UNE-EN 1340**.

Ud./Pallet	48 Uds.
Peso Aprox Ud.	38 Kg.
Peso Aprox. Pallet	1.810 Kg.
Uso	Obra Civil
Textura	Lisa

*Los pesos y medidas son valores orientativos.

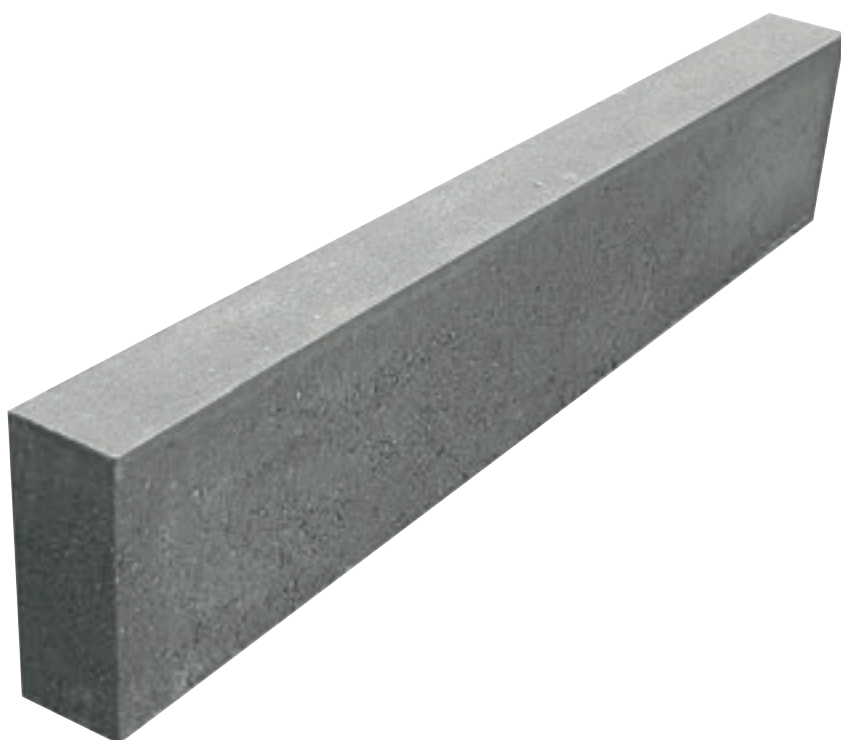

Medidas

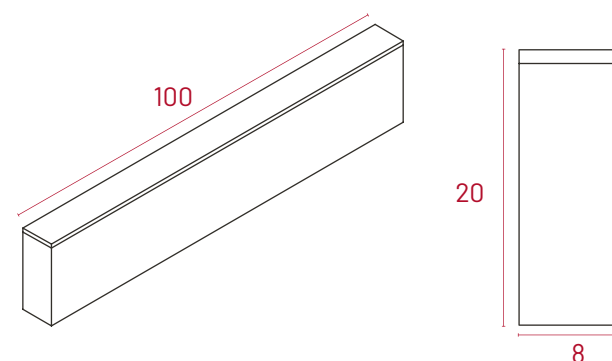

Colores disponibles



Gris

Propiedades del producto



Hidrofugado



Bicapa



Sostenible



Bordillo Duero DOBLE CAPA

100x20x8 Redondo

Especificaciones técnicas.

Fabricados conforme a la norma **UNE-EN 1340**.

Ud./Pallet	48 Uds.
Peso Aprox Ud.	36,5 Kg.
Peso Aprox. Pallet	1.750 Kg.
Uso	Obra Civil
Textura	Lisa

*Los pesos y medidas son valores orientativos.



Medidas

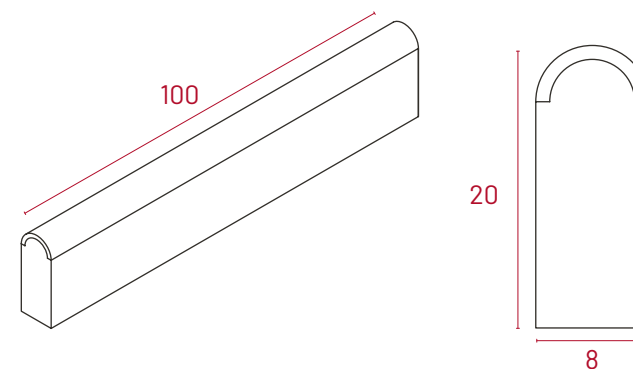

Colores disponibles



Gris

Propiedades del producto



Hidrofugado



Bicapa



Sostenible

Bordillo Duero DOBLE CAPA

100x20x10 Curvo

Especificaciones técnicas.

Fabricados conforme a la norma **UNE-EN 1340**.

Ud./Pallet	40 Uds.
Peso Aprox Ud.	45 Kg.
Peso Aprox. Pallet	1.800 Kg.
Uso	Obra Civil
Textura	Lisa

*Los pesos y medidas son valores orientativos.

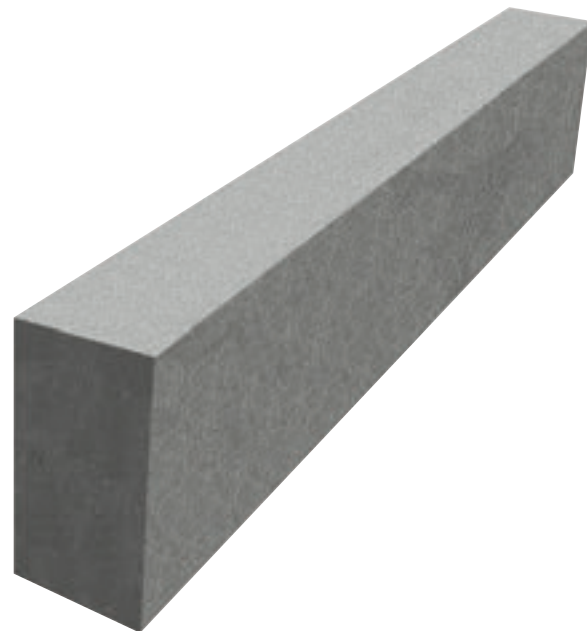

Medidas

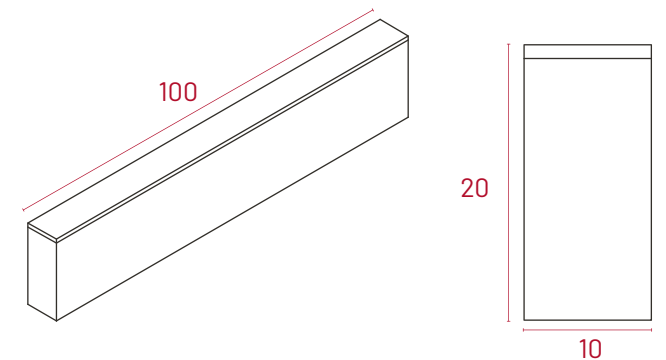

Colores disponibles



Gris

Propiedades del producto



Hidrofugado



Bicapa



Sostenible



Bordillo Duero DOBLE CAPA

100x20x10x9

Especificaciones técnicas.

Fabricados conforme a la norma **UNE-EN 1340**.

Ud./Pallet	40 Uds.
Peso Aprox Ud.	45 Kg.
Peso Aprox. Pallet	1.800 Kg.
Uso	Obra Civil
Textura	Lisa

*Los pesos y medidas son valores orientativos.

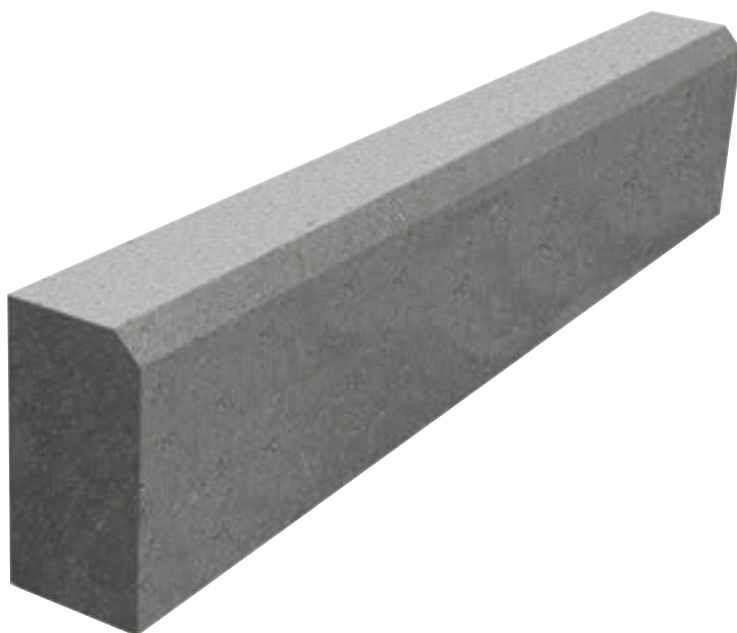

Medidas

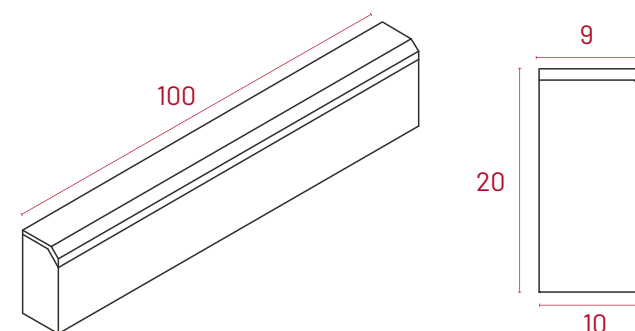

Colores disponibles



Gris

Propiedades del producto



Hidrofugado



Bicapa



Sostenible

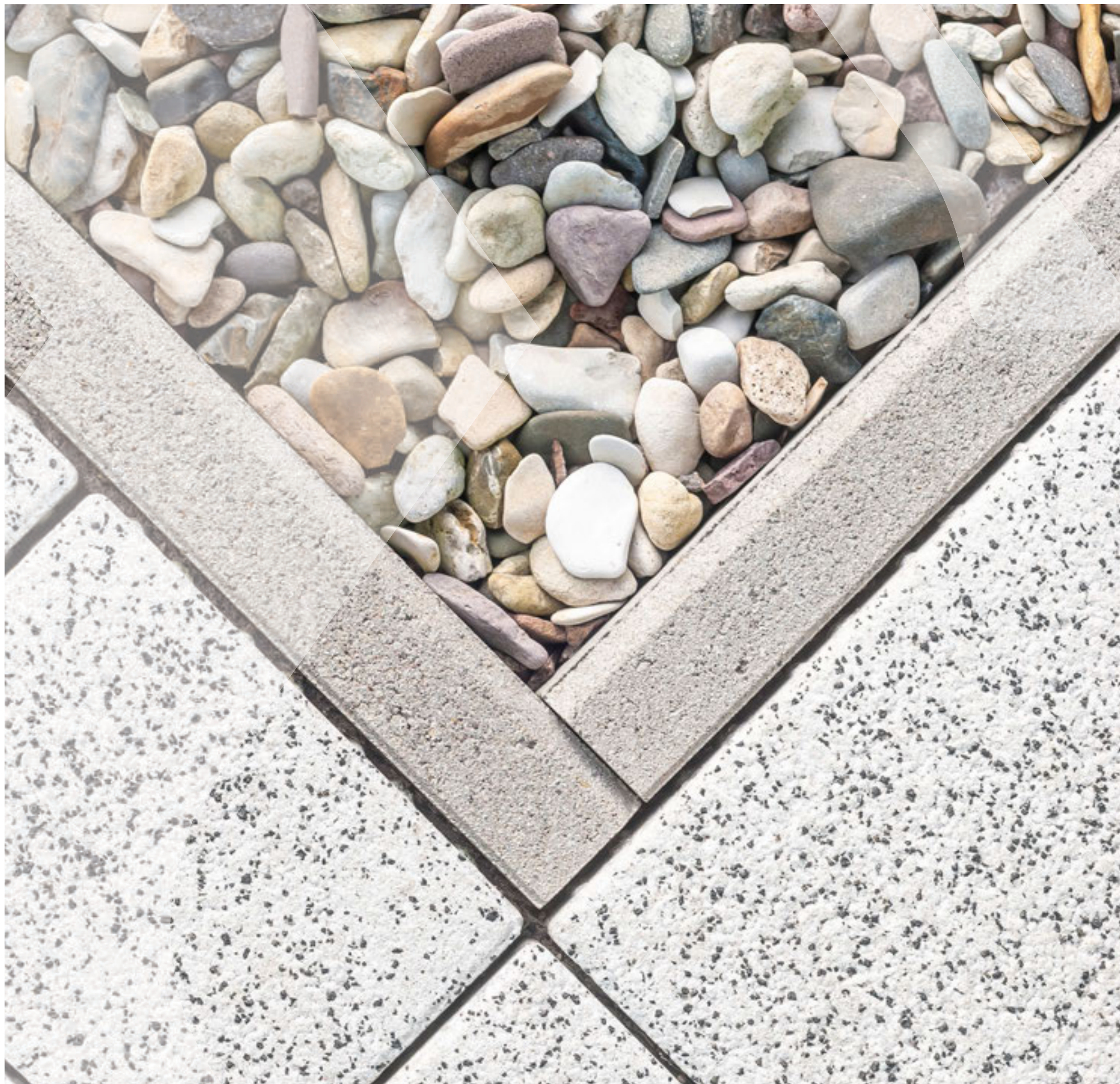



Bordillo Duero **DOBLE CAPA**

100x20x14x11

Especificaciones técnicas.

Fabricados conforme a la norma **UNE-EN 1340**.

Ud./Pallet	24 Uds.
Peso Aprox Ud.	64 Kg.
Peso Aprox. Pallet	1.540 Kg.
Uso	Obra Civil
Textura	Lisa

*Los pesos y medidas son valores orientativos.



Medidas

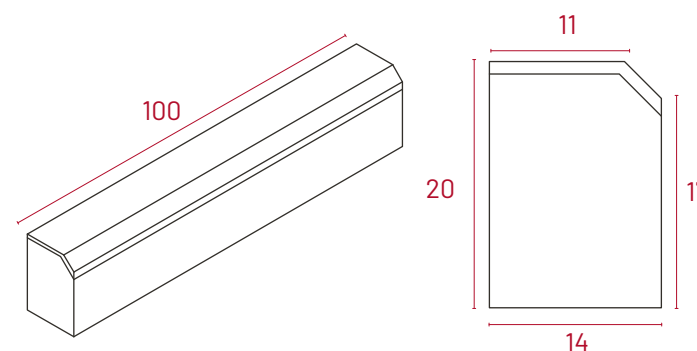

Colores disponibles



Gris

Propiedades del producto



Hidrofugado



Bicapa



Sostenible

Bordillo Duero **DOBLE CAPA**

100x25x12x9

Especificaciones técnicas.

Fabricados conforme a la norma **UNE-EN 1340**.

Ud./Pallet	24 Uds.
Peso Aprox Ud.	65 Kg.
Peso Aprox. Pallet	1.580 Kg.
Uso	Obra Civil
Textura	Lisa

*Los pesos y medidas son valores orientativos.



Medidas

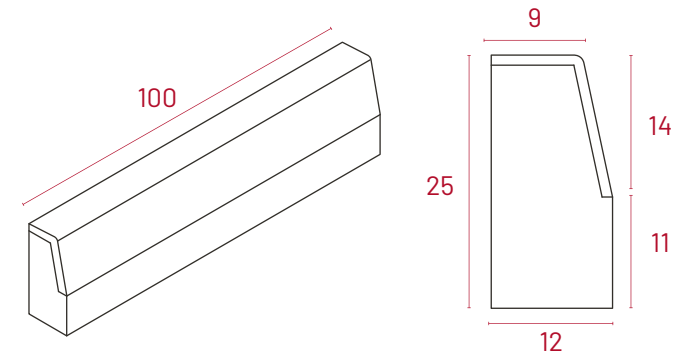

Colores disponibles



Gris

Propiedades del producto



Hidrofugado



Bicapa



Sostenible



Bordillo Duero DOBLE CAPA

100x25x15x12

Especificaciones técnicas.

Fabricados conforme a la norma **UNE-EN 1340**.

Ud./Pallet	16 Uds.
Peso Aprox Ud.	85 Kg.
Peso Aprox. Pallet	1.370 Kg.
Uso	Obra Civil
Textura	Lisa

*Los pesos y medidas son valores orientativos.



Medidas

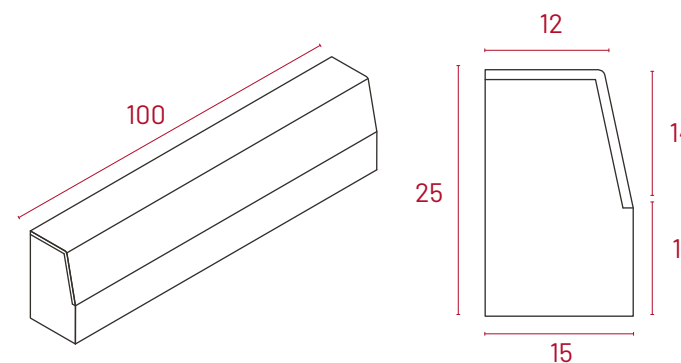

Colores disponibles



Gris

Propiedades del producto



Hidrofugado



Bicapa



Sostenible

Bordillo Duero **DOBLE CAPA**

100x28x15x12

Especificaciones técnicas.

Fabricados conforme a la norma **UNE-EN 1340**.

Ud./Pallet	12 Uds.
Peso Aprox Ud.	94,5 Kg.
Peso Aprox. Pallet	1.150 Kg.
Uso	Obra Civil
Textura	Lisa

*Los pesos y medidas son valores orientativos.



Medidas

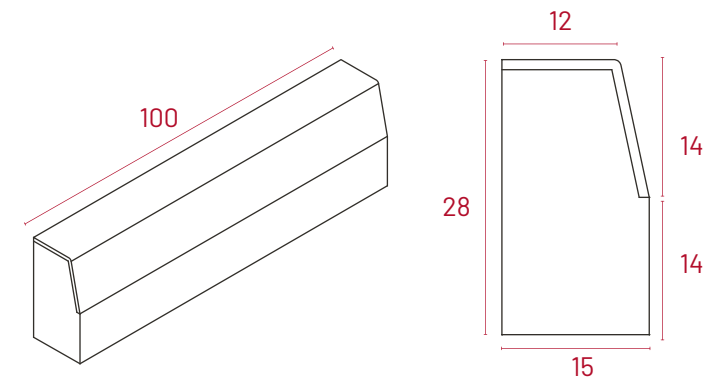

Colores disponibles



Gris

Propiedades del producto



Hidrofugado



Bicapa



Sostenible



Bordillo Duero DOBLE CAPA

100x28x17x14

Especificaciones técnicas.

Fabricados conforme a la norma **UNE-EN 1340**.

Ud./Pallet	12 Uds.
Peso Aprox Ud.	107 Kg.
Peso Aprox. Pallet	1.300 Kg.
Uso	Obra Civil
Textura	Lisa

*Los pesos y medidas son valores orientativos.



Medidas

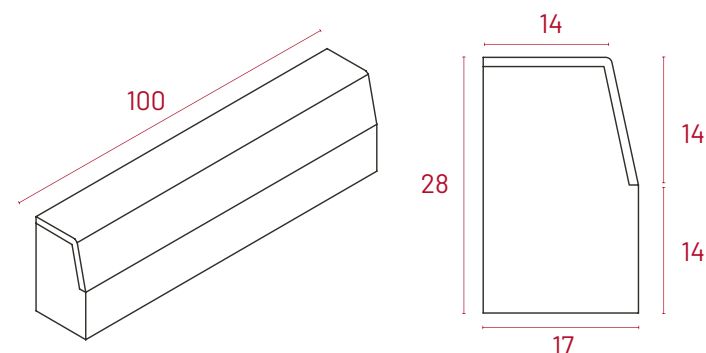

Colores disponibles



Gris

Propiedades del producto



Hidrofugado



Bicapa



Sostenible





Bordillo Duero DOBLE CAPA

50x25x15x12

Especificaciones técnicas.

Fabricados conforme a la norma **UNE-EN 1340**.

Ud./Pallet	40 Uds.
Peso Aprox Ud.	42 Kg.
Peso Aprox. Pallet	1.680 Kg.
Uso	Obra Civil
Textura	Lisa

*Los pesos y medidas son valores orientativos.



Medidas

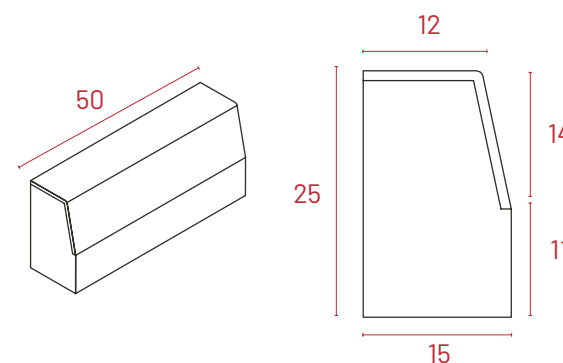

Colores disponibles



Gris

Propiedades del producto



Hidrofugado



Bicapa



Sostenible

Bordillo Duero DOBLE CAPA

Kaz 100x30x13x10

Especificaciones técnicas.

Fabricados conforme a la norma **UNE-EN 1340**.

Ud./Pallet	18 Uds.
Peso Aprox Ud.	83 Kg.
Peso Aprox. Pallet	1.500 Kg.
Uso	Obra Civil
Textura	Lisa

*Los pesos y medidas son valores orientativos.



Medidas

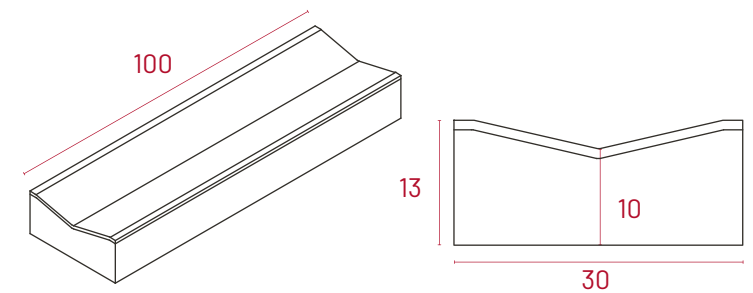

Colores disponibles



Gris

Propiedades del producto



Hidrofugado



Bicapa



Sostenible



Bordillo Duero DOBLE CAPA

Kaz 50x30x13x10

Especificaciones técnicas.

Fabricados conforme a la norma **UNE-EN 1340**.

Ud./Pallet	36 Uds.
Peso Aprox Ud.	42 Kg.
Peso Aprox. Pallet	1.540 Kg.
Uso	Obra Civil
Textura	Lisa

*Los pesos y medidas son valores orientativos.



Medidas

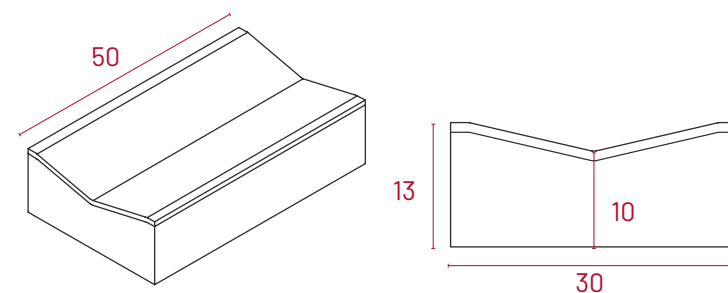

Colores disponibles



Gris

Propiedades del producto



Hidrofugado



Bicapa



Sostenible

Bordillo Duero DOBLE CAPA

Isleta 100x22x20x4

Especificaciones técnicas.

Fabricados conforme a la norma **UNE-EN 1340**.

Ud./Pallet	16 Uds.
Peso Aprox Ud.	90 Kg.
Peso Aprox. Pallet	1.450 Kg.
Uso	Obra Civil
Textura	Lisa

*Los pesos y medidas son valores orientativos.



Medidas

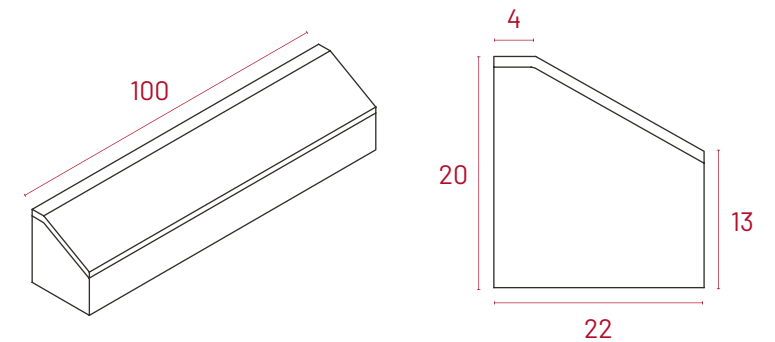

Colores disponibles



Gris

Propiedades del producto



Hidrofugado



Bicapa



Sostenible



Bordillo Duero DOBLE CAPA

Isleta 50x25x14x7,5

Especificaciones técnicas.

Fabricados conforme a la norma **UNE-EN 1340**.

Ud./Pallet	40 Uds.
Peso Aprox Ud.	37 Kg.
Peso Aprox. Pallet	1.495 Kg.
Uso	Obra Civil
Textura	Lisa

*Los pesos y medidas son valores orientativos.



Medidas

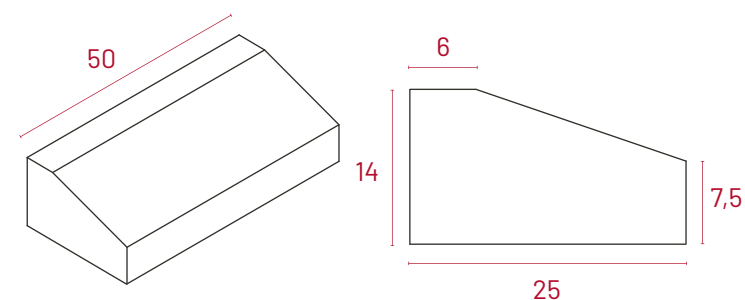

Colores disponibles



Gris

Propiedades del producto



Hidrofugado



Bicapa



Sostenible





Adoquines y baldosas

Global**EPD**

A VERIFIED ENVIRONMENTAL DECLARATION

Adoquines y Baldosas

ADOQUINES

Morales 10x10	49
Alcañices 12x12	50
Toro 20x10	51
Guareña 24x12	52
Coreses 23x12	54
Castellano 18-12-9x12	55
Benavente 20x16	56

BALDOSAS

Aliste 20x20	59
Tábara 30x30	60
Colegiata 40x20	61
Sayago 40x40	62
Tera 50x50	63
Sanabria 60x40	64
Celosía de Césped 50x33	65



Adoquines y Baldosas

ADOQUINES

Los adoquines de hormigón de Prefabricados Duero destacan por su resistencia a la abrasión y al desgaste, así como por su gran estabilidad, lo que los hace ideales para su uso en espacios exteriores con alto tráfico, como calles, plazas, parques y áreas públicas en general.

Adoquines

10x10 **MORALES**

Especificaciones técnicas.

Fabricados conforme a la norma **UNE-EN 1338**.

ESPESOR (h)	KG/M ²	M ² /PALET	KG/PALET	ARISTAS
6	140	5	700	45°
8	180	5	900	45°

*Los pesos y medidas son valores orientativos.



Disponible en:



Medidas

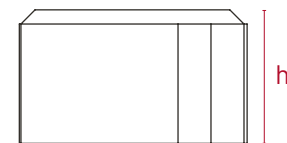
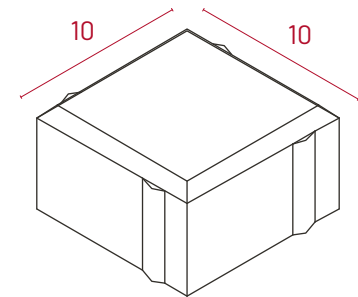

Colores disponibles



Gris Rojo Negro



Crema Tostado Blanco

Propiedades del producto



Hidrofugado



Bicapa



Sostenible



Ecológico



Adoquines

12x12 **ALCAÑICES**

Especificaciones técnicas.

Fabricados conforme a la norma **UNE-EN 1338**.

ESPESOR (h)	KG/M ²	M ² /PALET	KG/PALET	ARISTAS
6	140	6,45	930	45° / redonda

*Los pesos y medidas son valores orientativos.



Medidas

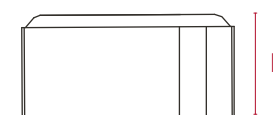
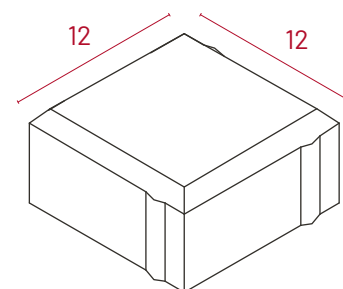

Colores disponibles



Gris Rojo Negro



Crema Tostado Blanco

Propiedades del producto



Hidrofugado



Bicapa



Sostenible



Ecológico

Disponible en:



Adoquines

20x10 TORO

Especificaciones técnicas.

Fabricados conforme a la norma **UNE-EN 1338**.

ESPESOR (h)	KG/M ²	M ² /PALET	KG/PALET	ARISTAS
6	140	10	1.400	45° / 90°
8	180	10	1.800	45° / 90°
10	220	7	1.585	45° / 90°

*Los pesos y medidas son valores orientativos.

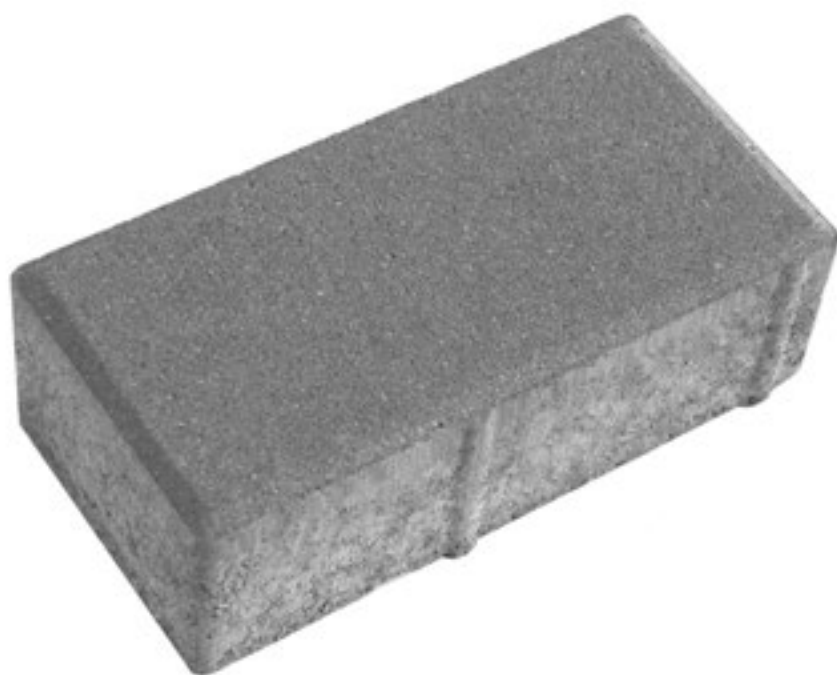

Medidas

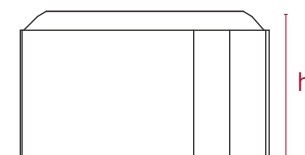
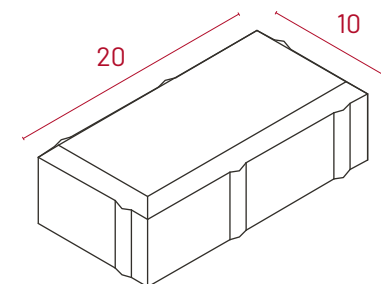

Colores disponibles



Gris Rojo Negro



Crema Tostado Blanco

Propiedades del producto



Hidrofugado



Bicapa



Sostenible



Ecológico

Disponible en:





Adoquines

24x12**GUAREÑA****Especificaciones técnicas.**Fabricados conforme a la norma **UNE-EN 1338**.

ESPESOR (h)	KG/M ²	M ² /PALET	KG/PALET	ARISTAS
6	140	9,22	1.330	45° / redonda

*Los pesos y medidas son valores orientativos.

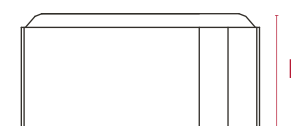
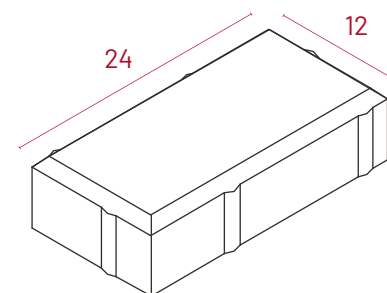
**Disponible en:****Medidas****Colores disponibles**

Gris Rojo Negro



Crema Tostado Blanco

Propiedades del producto

Hidrofugado



Bicapa



Sostenible



Ecológico





Adoquines

23x12 CORESES**Especificaciones técnicas.**Fabricados conforme a la norma **UNE-EN 1338**.

ESPESOR (h)	KG/M ²	M ² /PALET	KG/PALET	ARISTAS
6	140	9	1.260	45°
8	180	9	1.640	45°

*Los pesos y medidas son valores orientativos.

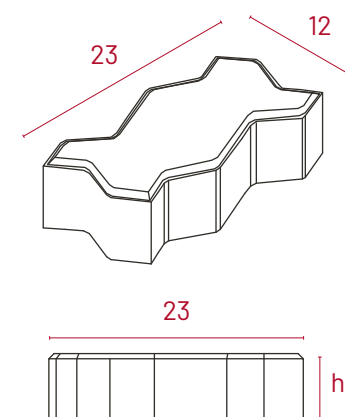
**Disponible en:****Medidas****Colores disponibles****Propiedades del producto**

Hidrofugado



Bicapa



Sostenible



Ecológico

Adoquines

18-12-9x12 CASTELLANO

Especificaciones técnicas.

Fabricados conforme a la norma **UNE-EN 1338**.

ESPESOR (h)	KG/M ²	M ² /PALET	KG/PALET	ARISTAS
6	140	10	1.400	45°
8	180	10	1.800	45°/ 90°

*Los pesos y medidas son valores orientativos.



Disponible en:



Medidas

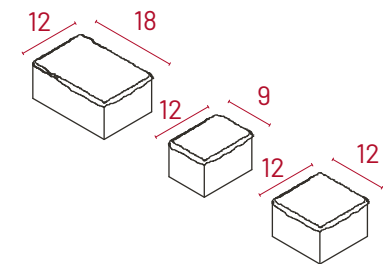

Colores disponibles



Gris Rojo Negro



Crema Tostado Blanco

Propiedades del producto



Hidrofugado



Bicapa



Sostenible



Ecológico



Adoquines

20x16 **BENAVENTE**

Especificaciones técnicas.

Fabricados conforme a la norma **UNE-EN 1338**.

ESPESOR (h)	KG/M ²	M ² /PALET	KG/PALET	ARISTAS
8	180	8,6	1.548	45°

*Los pesos y medidas son valores orientativos.



Disponible en:



Medidas

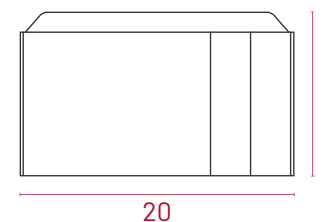
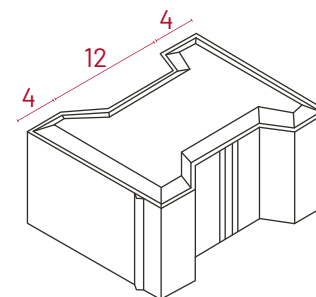

Colores disponibles



Propiedades del producto



Hidrofugado



Bicapa



Sostenible



Ecológico

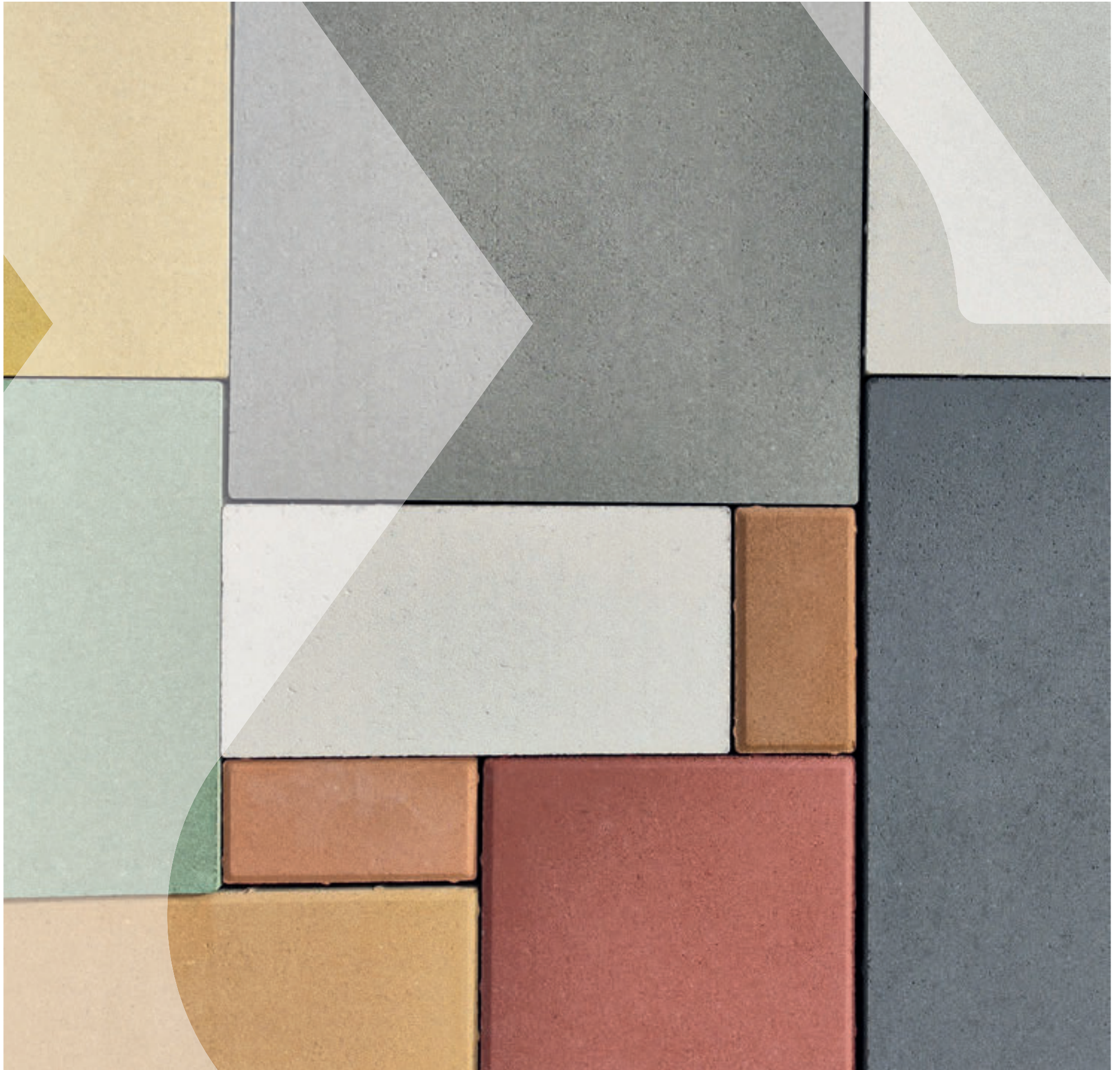



Adoquines y Baldosas

BALDOSAS

Los beneficios del uso de baldosas de hormigón de Prefabricados Duero incluyen su alta resistencia, durabilidad y facilidad de mantenimiento. Además, estas baldosas son resistentes al deslizamiento y ofrecen una excelente tracción en superficies mojadas, lo que las hace ideales para áreas al aire libre, como patios, piscinas, terrazas y caminos de jardín.

Baldosas

20x20 ALISTE

Especificaciones técnicas.

Fabricados conforme a la norma **UNE-EN 1339**.

ESPESOR (h)	KG/M ²	M ² /PALET	KG/PALET	ARISTAS
6	140	10	1.400	45° / 90°
8	180	10	1.850	45° / 90°

*Los pesos y medidas son valores orientativos.



Medidas

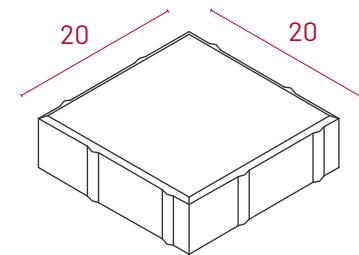

Colores disponibles



Gris Rojo Negro



Crema Tostado Blanco

Propiedades del producto



Hidrofugado



Bicapa



Sostenible



Ecológico

Disponible en:





Baldosas

30x30 TÁBARA

Especificaciones técnicas.

Fabricados conforme a la norma **UNE-EN 1339**.

ESPESOR (h)	KG/M ²	M ² /PALET	KG/PALET	ARISTAS
6	140	8,1	1.134	45°

*Los pesos y medidas son valores orientativos.



Disponible en:



Medidas

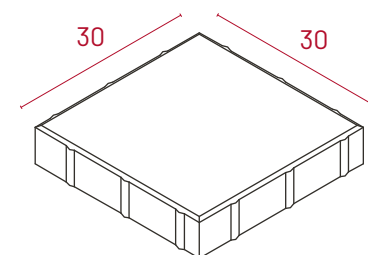

Colores disponibles



Gris Rojo Negro



Crema Tostado Blanco

Propiedades del producto



Hidrofugado



Bicapa



Sostenible



Ecológico

Baldosas

40x20 COLEGIATA

Especificaciones técnicas.

Fabricados conforme a la norma **UNE-EN 1339**.

ESPESOR (h)	KG/M ²	M ² /PALET	KG/PALET	ARISTAS
6	140	9,6	1.400	45°/90°
8	180	9,6	1.750	90°

*Los pesos y medidas son valores orientativos.



Medidas

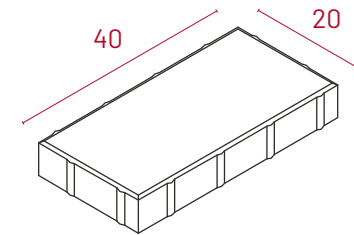

Colores disponibles



Gris Rojo Negro



Crema Tostado Blanco

Propiedades del producto



Hidrofugado



Bicapa



Sostenible



Ecológico

Disponible en:





Baldosas

40x40 **SAYAGO**

Especificaciones técnicas.

Fabricados conforme a la norma **UNE-EN 1339**.

ESPESOR (h)	KG/M ²	M ² /PALET	KG/PALET	ARISTAS
6	140	9,6	1.370	90°

*Los pesos y medidas son valores orientativos.



Medidas

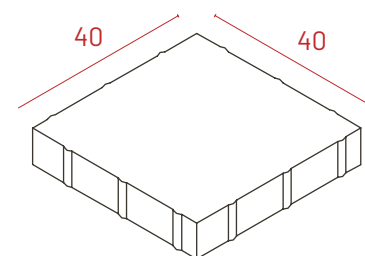

Colores disponibles



Gris Rojo Negro



Crema Tostado Blanco

Propiedades del producto



Hidrofugado



Bicapa



Sostenible



Ecológico

Disponible en:



Baldosas

50x50

TERA

Especificaciones técnicas.

Fabricados conforme a la norma **UNE-EN 1339**.

ESPESOR (h)	KG/M ²	M ² /PALET	KG/PALET	ARISTAS
6	140	10	1.420	90°
8	180	10	1.850	90°

*Los pesos y medidas son valores orientativos.



Disponible en:



Medidas

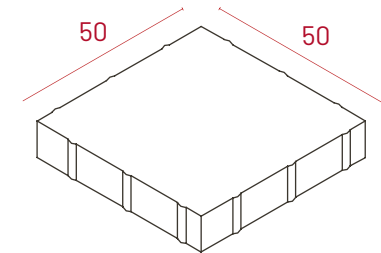

Colores disponibles



Gris

Rojo

Negro



Crema Tostado Blanco

Propiedades del producto



Hidrofugado



Bicapa



Sostenible



Ecológico

Baldosas

60x40 **SANABRIA**

Especificaciones técnicas.

Fabricados conforme a la norma **UNE-EN 1339**.

ESPESOR (h)	KG/M ²	M ² /PALET	KG/PALET	ARISTAS
6	140	11,52	1.630	90°
8	180	10,08	1.850	90°

*Los pesos y medidas son valores orientativos.

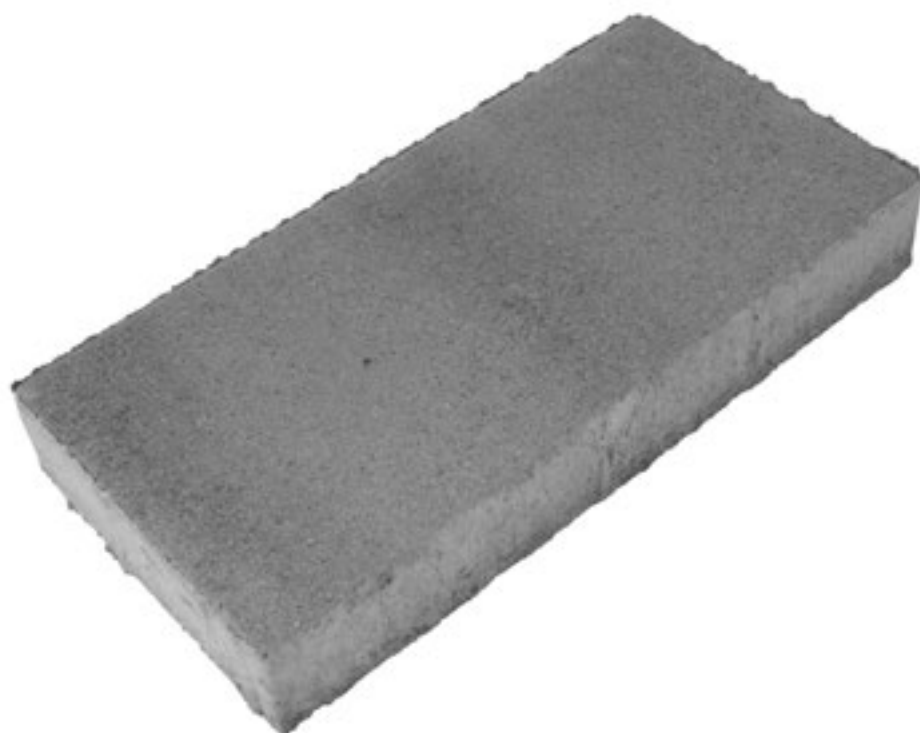

Medidas

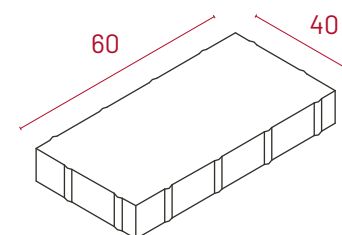

Colores disponibles



Propiedades del producto



Hidrofugado



Bicapa



Sostenible



Ecológico

Disponible en:



Baldosas

50x33 CELOSÍA DE CÉSPED

Especificaciones técnicas.

Fabricados conforme a la norma **UNE-EN 1339**.

ESPESOR (h)	KG/M ²	M ² /PALET	KG/PALET	ARISTAS
10	150	6	910	45°

*Los pesos y medidas son valores orientativos.



Medidas

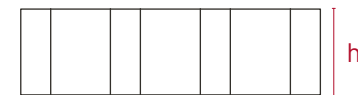
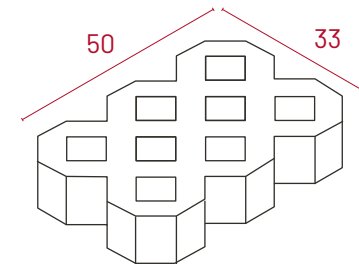

Colores disponibles



Gris

Propiedades del producto



Hidrofugado



Ecológico



Sostenible

Disponible en:





Baldosa Hidráulica

Global **EPD**

A VERIFIED ENVIRONMENTAL DECLARATION

Baldosa Hidráulica

20x20

4 pastillas	69
18 pastillas	70
Pétrea	71
Pergamino	72
Botones	74
Lisa	75
Granitor	76

33x33

Pétrea	89
Pizarra	90
Pergamino	91
Botones	92
Granitor	93
Guía (direccional)	94

30x30

Pétrea	79
Petreofín	80
Pizarra	81
Pergamino	82
Botones	83
36 pastillas	84
Granitor	85
Guía (direccional)	86

40x40

Pétrea	97
Petreofin	98
Pizarra	99
Pergamino	100
Botones	102
64 Pastillas	103
Granitor	104
Guía (direccional)	105
Canto lavado	106

60x40

Pétrea	109
Pizarra	110
Pergamino	111
Granitor	112



Baldosa Hidráulica

20x20

Las baldosas hidráulicas de hormigón son el suelo ideal que estás buscando para tu proyecto. Estas baldosas son pavimentos de alta resistencia con diferentes dibujos, acabados y colores, lo que las convierte en una opción muy versátil que puede utilizarse en una amplia variedad de proyectos.



Baldosa Hidráulica 20x20

4 Pastillas

Especificaciones técnicas.

Fabricados conforme a la norma **UNE-EN 13748-2**.

ESPESOR (h)	KG/M ²	M ² /PALET	KG/PALET
4	93	17,92	1.700

*Los pesos y medidas son valores orientativos.



Medidas

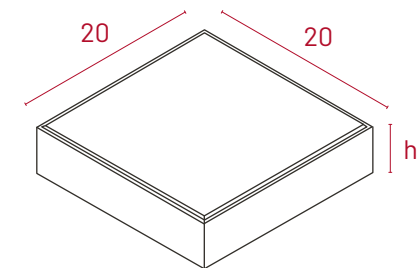

Colores disponibles



Gris

Rojo

Negro

Propiedades del producto



Hidrofugado



Bicapa



Sostenible



Baldosa Hidráulica **20x20**

18 Pastillas

Especificaciones técnicas.

Fabricados conforme a la norma **UNE-EN 13748-2**.

ESPESOR (h)	KG/M ²	M ² /PALET	KG/PALET
4	93	17,92	1.700

*Los pesos y medidas son valores orientativos.



Medidas

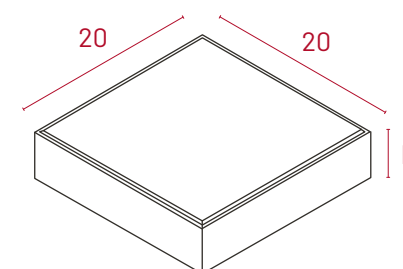

Colores disponibles



Gris Rojo Negro

Propiedades del producto



Hidrofugado



Bicapa



Sostenible



Baldosa Hidráulica 20x20

Pétrea

Especificaciones técnicas.

Fabricados conforme a la norma **UNE-EN 13748-2**.

ESPESOR (h)	KG/M ²	M ² /PALET	KG/PALET
4	93	17,92	1.700
6	130	12,80	1.740

*Los pesos y medidas son valores orientativos.



Medidas

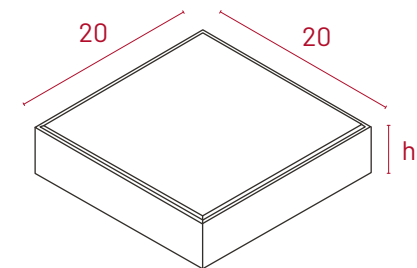

Colores disponibles

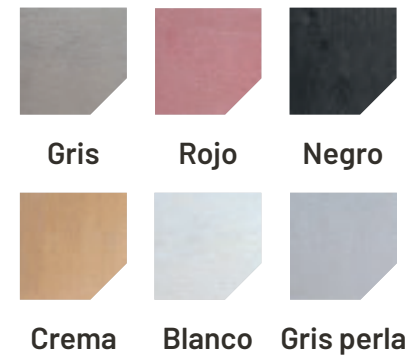

Propiedades del producto





Baldosa Hidráulica **20x20**

Pergamino

Especificaciones técnicas.

Fabricados conforme a la norma **UNE-EN 13748-2**.

ESPESOR (h)	KG/M ²	M ² /PALET	KG/PALET
4	93	17,92	1.700

*Los pesos y medidas son valores orientativos.

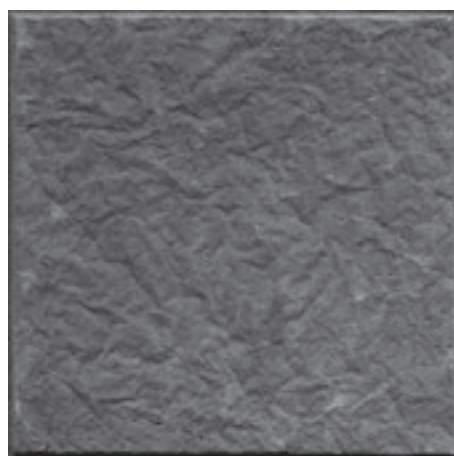

Medidas

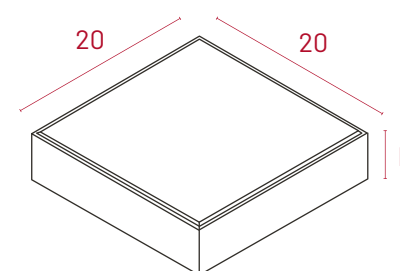

Colores disponibles

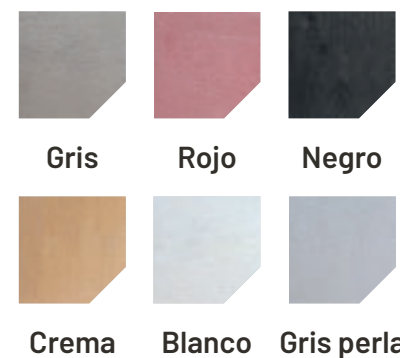

Propiedades del producto

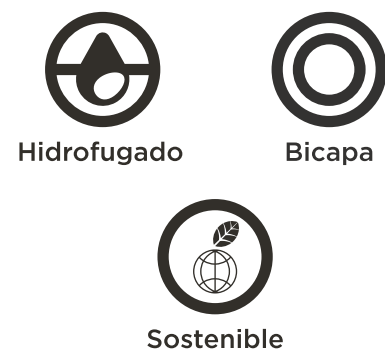





Baldosa Hidráulica **20x20**

Botones

Especificaciones técnicas.

Fabricados conforme a la norma **UNE-EN 13748-2**.

ESPESOR (h)	KG/M ²	M ² /PALET	KG/PALET
4	93	17,92	1.700
6	130	12,80	1.740

*Los pesos y medidas son valores orientativos.

Medidas

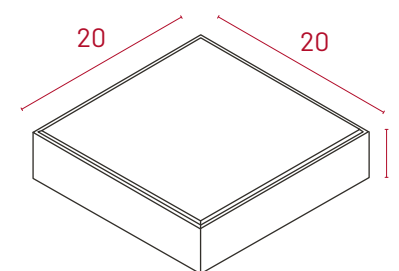

Colores disponibles

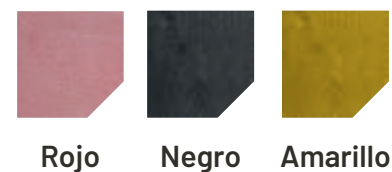

Rojo

Negro

Amarillo

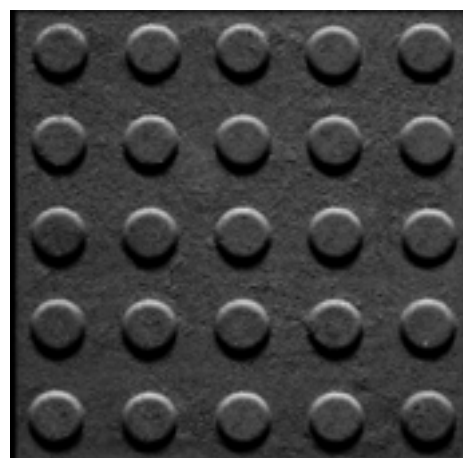

Propiedades del producto



Hidrofugado



Bicapa



Sostenible



Baldosa Hidráulica **20x20**

Lisa

Especificaciones técnicas.

Fabricados conforme a la norma **UNE-EN 13748-2**.

ESPESOR (h)	KG/M ²	M ² /PALET	KG/PALET
4	90	17,92	1.700
6	130	12,80	1.740

*Los pesos y medidas son valores orientativos.



Medidas

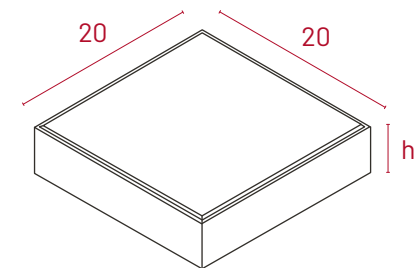

Colores disponibles

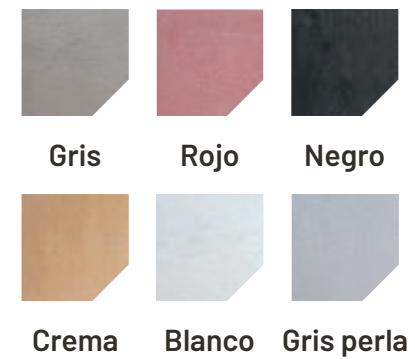

Propiedades del producto

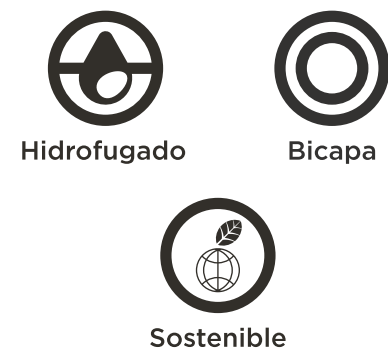



Baldosa Hidráulica **20x20**

Granitor

Especificaciones técnicas.

Fabricados conforme a la norma **UNE-EN 13748-2**.

ESPESOR (h)	KG/M ²	M ² /PALET	KG/PALET
4	94	17,92	1.740
6	132	12,80	1.780

*Los pesos y medidas son valores orientativos.



Medidas

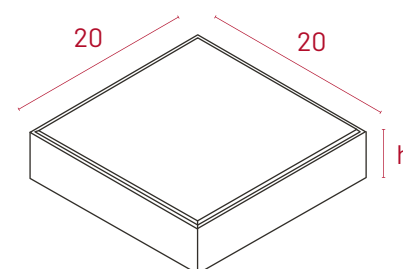

Colores disponibles



Rojo



Negro



Gris perla

Propiedades del producto



Hidrofugado



Bicapa



Sostenible





Baldosa Hidráulica

30x30

Nuestras baldosas hidráulicas de hormigón son la solución perfecta para aquellos que buscan un pavimento resistente y duradero con un acabado estético impecable. Además, gracias a nuestra capacidad de innovación, podemos crear diseños personalizados para cada proyecto, lo que permite que cada obra tenga su propia identidad y estilo.



Baldosa Hidráulica 30x30

Pétrea

Especificaciones técnicas.

Fabricados conforme a la norma **UNE-EN 13748-2**.

ESPESOR (h)	KG/M ²	M ² /PALET	KG/PALET
4	93	12,96	1.210
6	130	9,72	1.300

*Los pesos y medidas son valores orientativos.



Medidas

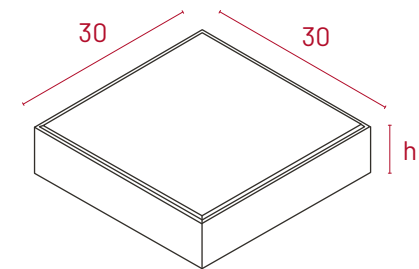

Colores disponibles

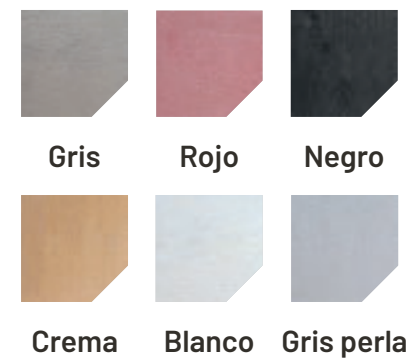

Propiedades del producto





Baldosa Hidráulica **30x30**

Petreofin

Especificaciones técnicas.

Fabricados conforme a la norma **UNE-EN 13748-2**.

ESPESOR (h)	KG/M ²	M ² /PALET	KG/PALET
4	90	12,96	1.210
6	130	9,72	1.300

*Los pesos y medidas son valores orientativos.



Medidas

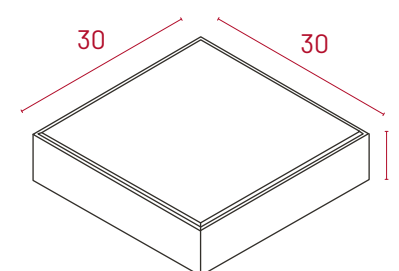

Colores disponibles

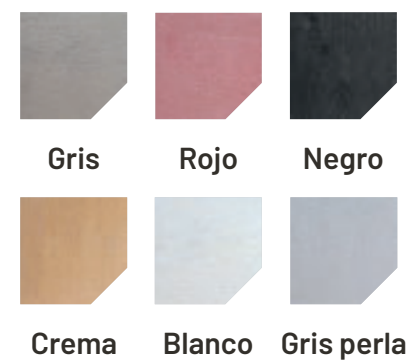

Propiedades del producto





Baldosa Hidráulica 30x30

Pizarra

Especificaciones técnicas.

Fabricados conforme a la norma **UNE-EN 13748-2**.

ESPESOR (h)	KG/M ²	M ² /PALET	KG/PALET
4	93	12,96	1.210
6	130	9,72	1.300

*Los pesos y medidas son valores orientativos.



Medidas

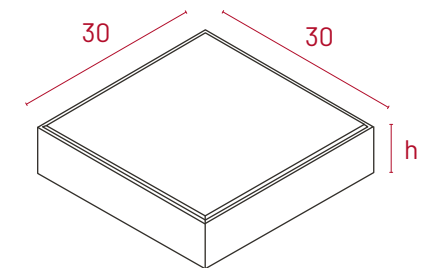

Colores disponibles

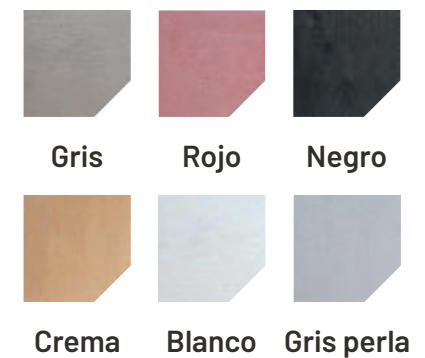

Propiedades del producto





Baldosa Hidráulica **30x30**

Pergamino

Especificaciones técnicas.

Fabricados conforme a la norma **UNE-EN 13748-2**.

ESPESOR (h)	KG/M ²	M ² /PALET	KG/PALET
4	93	12,96	1.210

*Los pesos y medidas son valores orientativos.

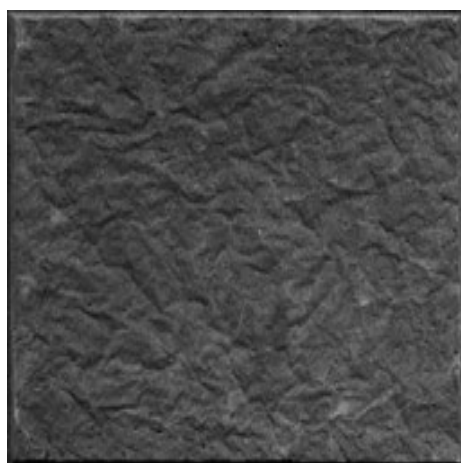

Medidas

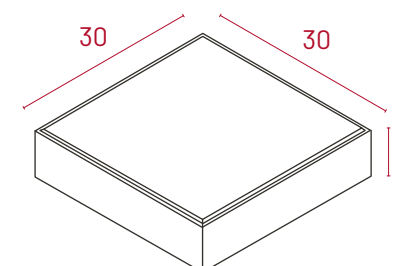

Colores disponibles

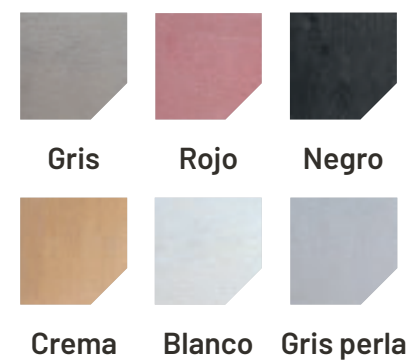

Propiedades del producto

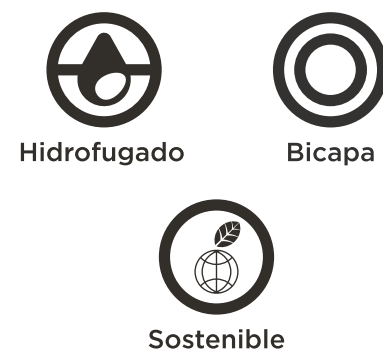



Baldosa Hidráulica 30x30

Botones

Especificaciones técnicas.

Fabricados conforme a la norma **UNE-EN 13748-2**.

ESPESOR (h)	KG/M ²	M ² /PALET	KG/PALET
4	93	12,96	1.210
6	130	9,72	1.300

*Los pesos y medidas son valores orientativos.



Medidas

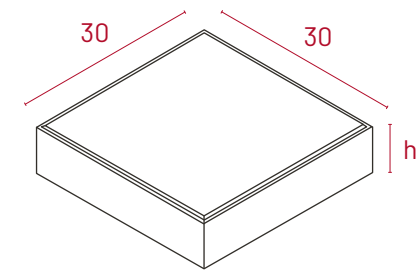

Colores disponibles

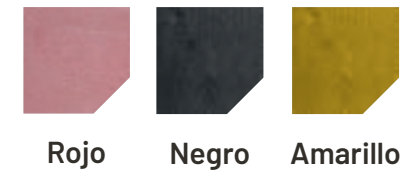

Rojo

Negro

Amarillo

Propiedades del producto



Hidrofugado



Bicapa



Sostenible



Baldosa Hidráulica 30x30

36 Pastillas

Especificaciones técnicas.

Fabricados conforme a la norma **UNE-EN 13748-2**.

ESPESOR (h)	KG/M ²	M ² /PALET	KG/PALET
4	90	12,96	1.180

*Los pesos y medidas son valores orientativos.

Medidas

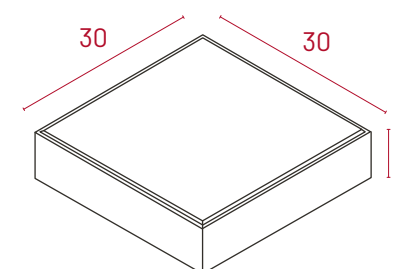

Colores disponibles

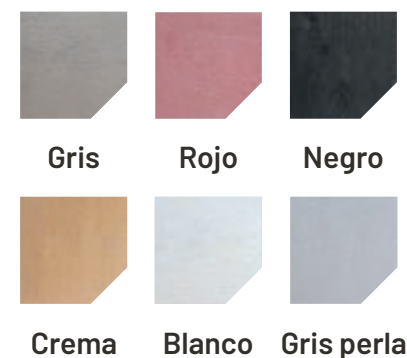

Propiedades del producto





Baldosa Hidráulica 30x30

Granitor

Especificaciones técnicas.

Fabricados conforme a la norma **UNE-EN 13748-2**.

ESPESOR (h)	KG/M ²	M ² /PALET	KG/PALET
4	94	12,96	1.230
6	132	9,72	1.340

*Los pesos y medidas son valores orientativos.



Medidas

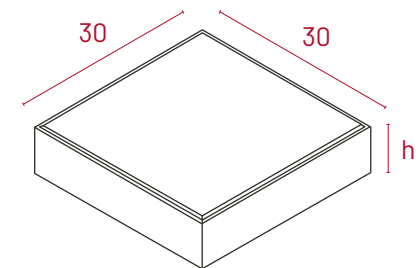

Colores disponibles



Propiedades del producto



Hidrofugado



Bicapa



Sostenible



Baldosa Hidráulica **30x30**

Guía (Direccional)

Especificaciones técnicas.

Fabricados conforme a la norma **UNE-EN 13748-2**.

ESPESOR (h)	KG/M ²	M ² /PALET	KG/PALET
4	93	12,96	1.210
6	130	9,72	1.300

*Los pesos y medidas son valores orientativos.

Medidas

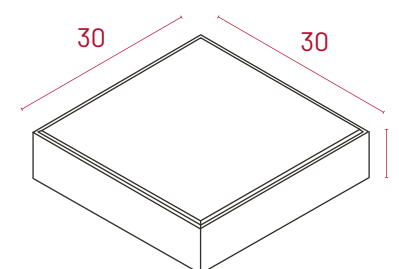

Colores disponibles

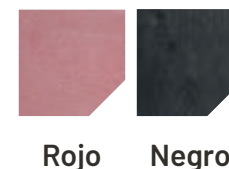

Rojo Negro



Propiedades del producto



Hidrofugado



Bicapa



Sostenible





Baldosa Hidráulica

33x33

En Prefabricados Duero, nos aseguramos de que todas nuestras baldosas hidráulicas de hormigón sean sometidas a un continuo y exigente control de fabricación para garantizar que cumplen con nuestros altos estándares de calidad. De esta manera, podemos asegurarnos de que nuestros productos cumplen con las expectativas de nuestros clientes en términos de durabilidad, resistencia y estética.



Baldosa Hidráulica **33x33**

Pétrea

Especificaciones técnicas.

Fabricados conforme a la norma **UNE-EN 13748-2**.

ESPESOR (h)	KG/M ²	M ² /PALET	KG/PALET
4	93	16	1.485
5	110	12,88	1.440

*Los pesos y medidas son valores orientativos.



Medidas

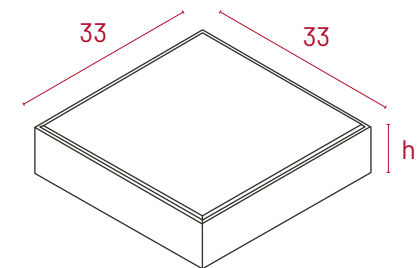

Colores disponibles

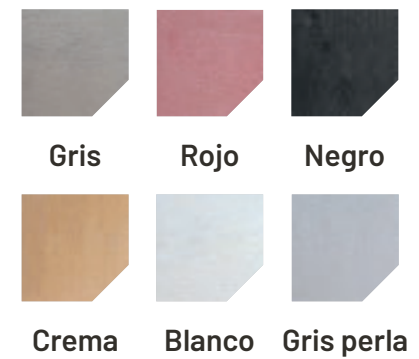

Propiedades del producto





Baldosa Hidráulica **33x33**

Pizarra

Especificaciones técnicas.

Fabricados conforme a la norma **UNE-EN 13748-2**.

ESPESOR (h)	KG/M ²	M ² /PALET	KG/PALET
4	93	16	1.485
5	110	12,88	1.440

*Los pesos y medidas son valores orientativos.



Medidas

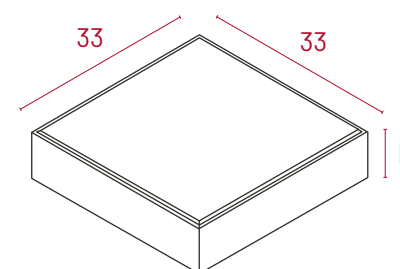

Colores disponibles

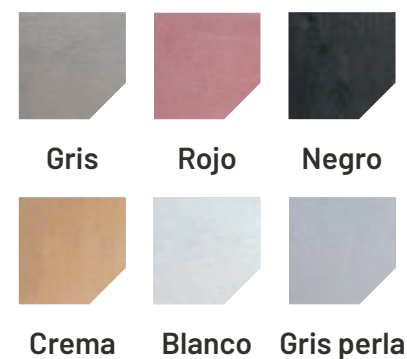

Propiedades del producto



Hidrofugado



Bicapa



Sostenible



Baldosa Hidráulica **33x33**

Pergamino

Especificaciones técnicas.

Fabricados conforme a la norma **UNE-EN 13748-2**.

ESPESOR (h)	KG/M ²	M ² /PALET	KG/PALET
4	93	16	1.485
5	110	12,88	1.440

*Los pesos y medidas son valores orientativos.

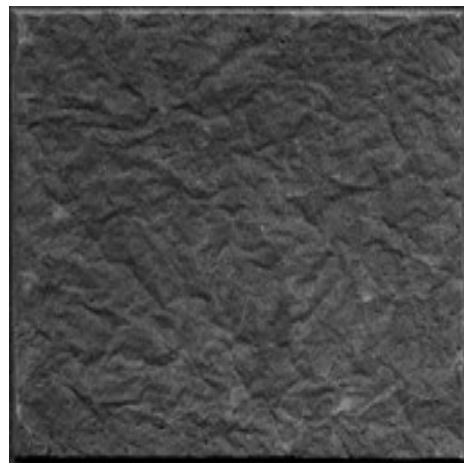

Medidas

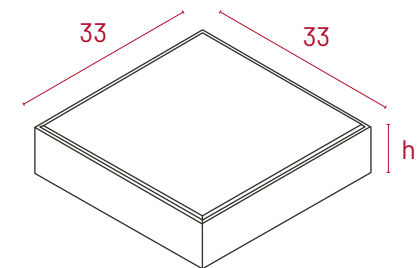

Colores disponibles

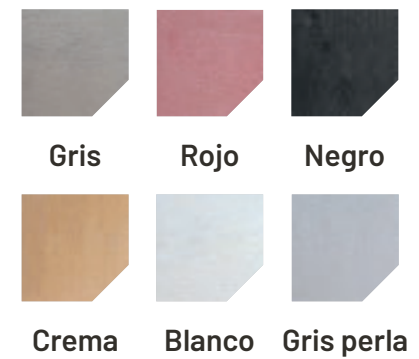

Propiedades del producto



Hidrofugado



Bicapa



Sostenible



Baldosa Hidráulica **33x33**

Botones

Especificaciones técnicas.

Fabricados conforme a la norma **UNE-EN 13748-2**.

ESPESOR (h)	KG/M ²	M ² /PALET	KG/PALET
4	93	16	1.485
5	110	12,88	1.440

*Los pesos y medidas son valores orientativos.

Medidas

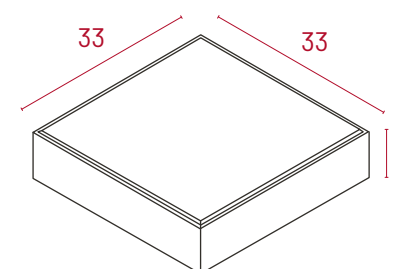

Colores disponibles

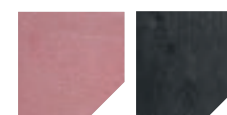

Rojo Negro



Propiedades del producto



Hidrofugado



Bicapa



Sostenible



Difuminado



Baldosa Hidráulica **33x33**

Granitor

Especificaciones técnicas.

Fabricados conforme a la norma **UNE-EN 13748-2**.

ESPESOR (h)	KG/M ²	M ² /PALET	KG/PALET
4	94	16	1.500
5	112	12,88	1.500

*Los pesos y medidas son valores orientativos.



Medidas

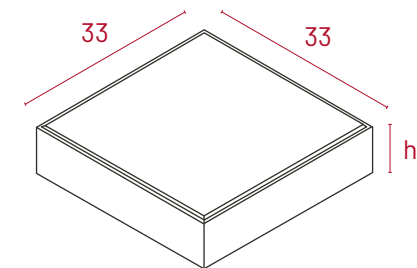

Colores disponibles



Propiedades del producto



Hidrofugado



Bicapa



Sostenible



Baldosa Hidráulica **33x33**

Guía (Direccional)

Especificaciones técnicas.

Fabricados conforme a la norma **UNE-EN 13748-2**.

ESPESOR (h)	KG/M ²	M ² /PALET	KG/PALET
4	93	12,96	1.210
6	130	9,72	1.300

*Los pesos y medidas son valores orientativos.



Medidas

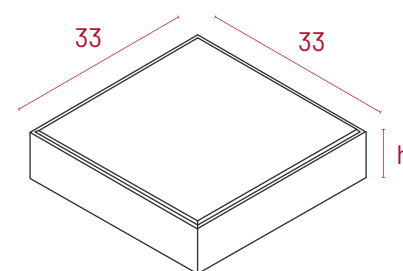

Colores disponibles



Propiedades del producto



Hidrofugado



Bicapa



Sostenible

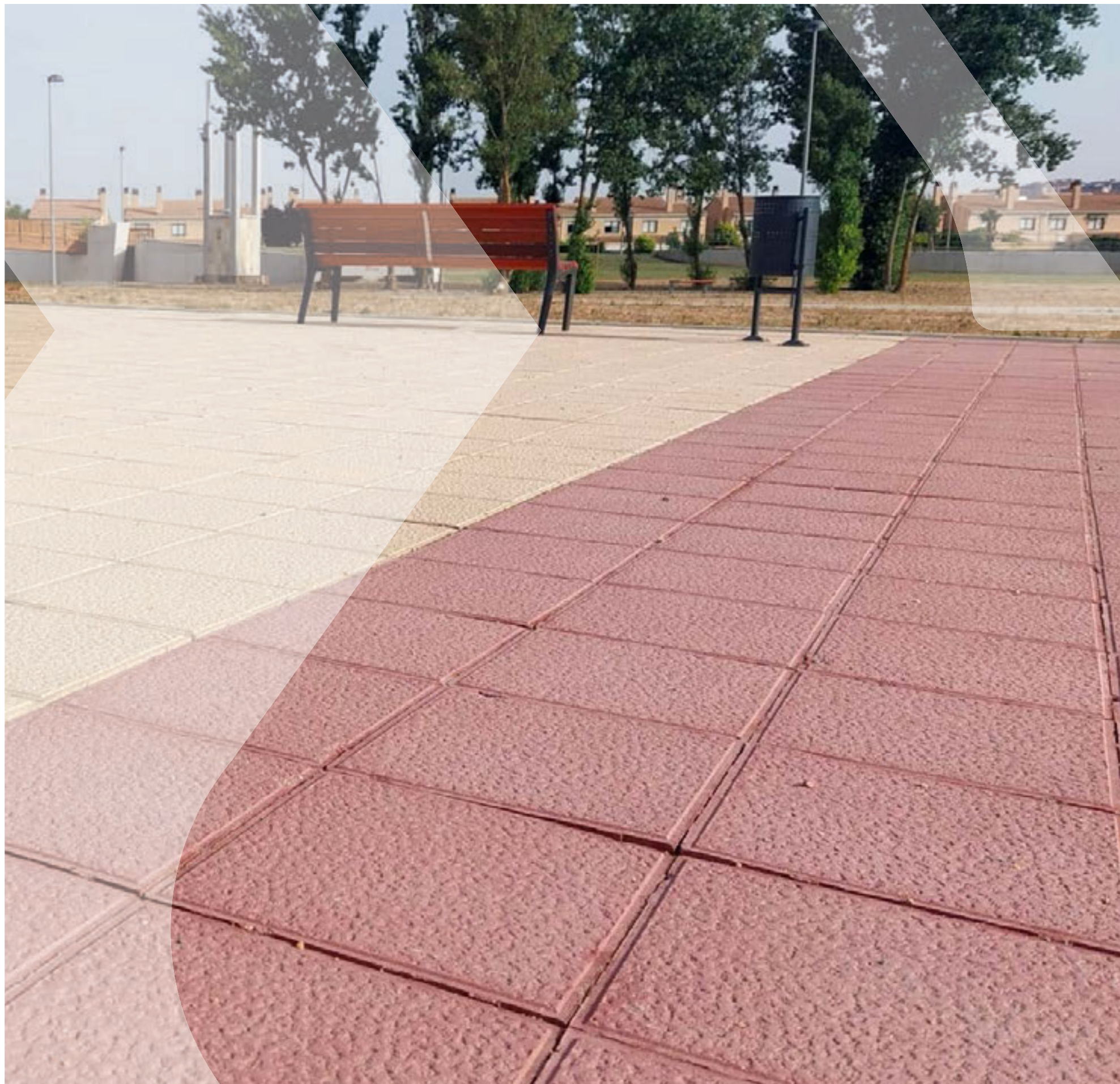



Baldosa Hidráulica

40x40

Si buscas un pavimento resistente, versátil y con un acabado estético impecable, las baldosas hidráulicas de hormigón de Prefabricados Duero son la opción perfecta. Ya sea que estés trabajando en una urbanización residencial o en un proyecto comercial, podemos ofrecerte una solución personalizada y de alta calidad que se adapte a tus necesidades.



Baldosa Hidráulica 40x40

Pétrea

Especificaciones técnicas.

Fabricados conforme a la norma **UNE-EN 13748-2**.

ESPESOR (h)	KG/M ²	M ² /PALET	KG/PALET
4	93	17,92	1.660
5	110	15,36	1.720

*Los pesos y medidas son valores orientativos.



Medidas

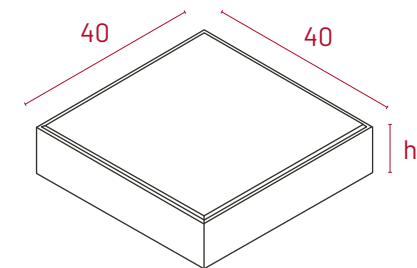

Colores disponibles

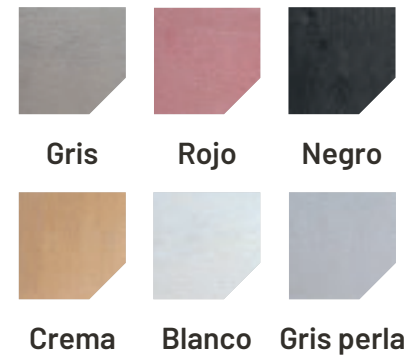

Propiedades del producto





Baldosa Hidráulica **40x40**

Petreofin

Especificaciones técnicas.

Fabricados conforme a la norma **UNE-EN 13748-2**.

ESPESOR (h)	KG/M ²	M ² /PALET	KG/PALET
4	93	17,92	1.660
5	110	15,36	1.720

*Los pesos y medidas son valores orientativos.

Medidas

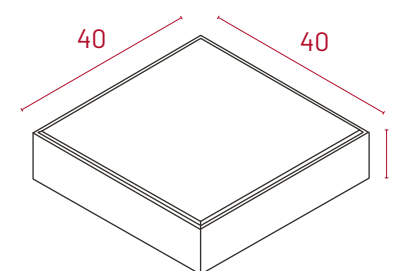

Colores disponibles

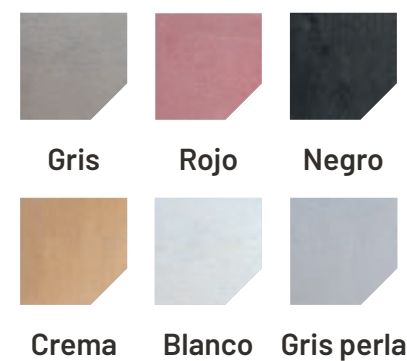

Propiedades del producto

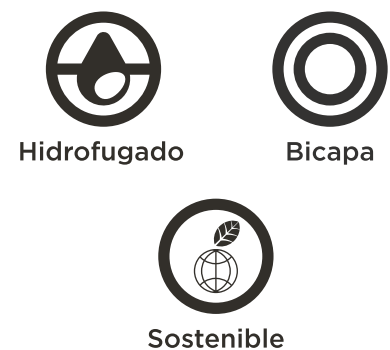



Baldosa Hidráulica 40x40

Pizarra

Especificaciones técnicas.

Fabricados conforme a la norma **UNE-EN 13748-2**.

ESPESOR (h)	KG/M ²	M ² /PALET	KG/PALET
4	93	17,92	1.660
5	110	15,36	1.720

*Los pesos y medidas son valores orientativos.



Medidas

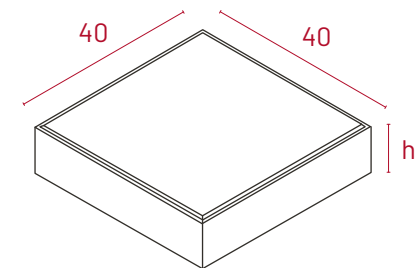

Colores disponibles

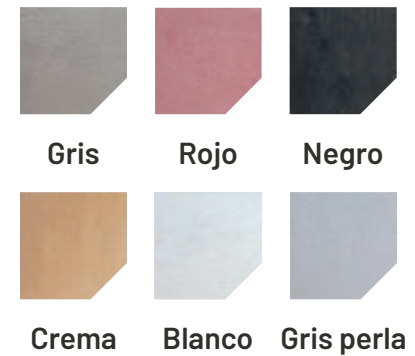

Propiedades del producto



Sostenible



Baldosa Hidráulica 40x40

Pergamino

Especificaciones técnicas.

Fabricados conforme a la norma **UNE-EN 13748-2**.

ESPESOR (h)	KG/M ²	M ² /PALET	KG/PALET
4	93	17,92	1.660
5	110	15,36	1.720

*Los pesos y medidas son valores orientativos.

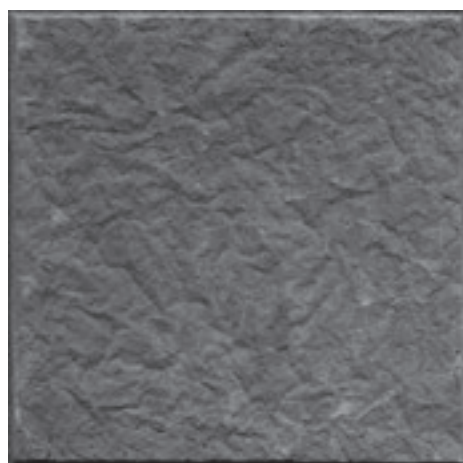

Medidas

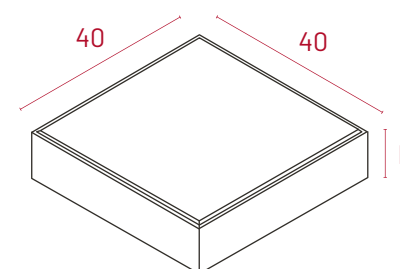

Colores disponibles

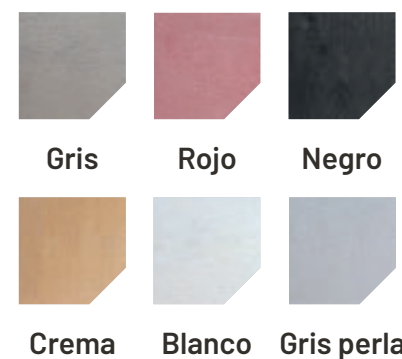

Propiedades del producto

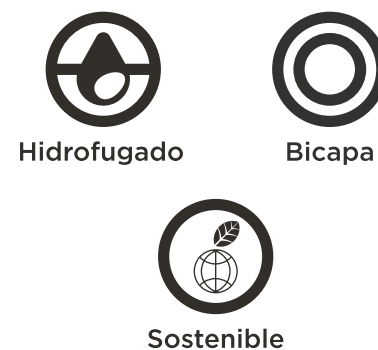





Baldosa Hidráulica **40x40**

Botones

Especificaciones técnicas.

Fabricados conforme a la norma **UNE-EN 13748-2**.

ESPESOR (h)	KG/M ²	M ² /PALET	KG/PALET
4	93	17,92	1.660
5	110	15,36	1.720

*Los pesos y medidas son valores orientativos.

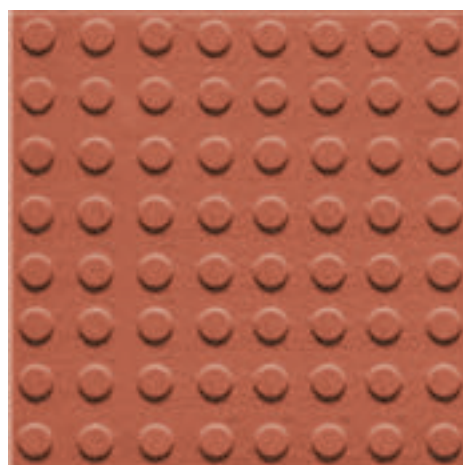

Medidas

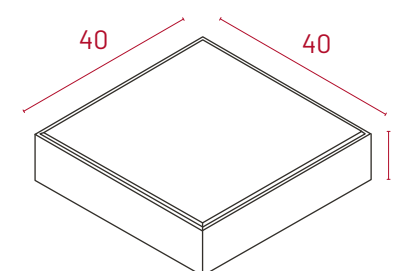

Colores disponibles



Rojo Negro

Propiedades del producto



Hidrofugado



Bicapa



Sostenible



Baldosa Hidráulica 40x40

64 Pastillas

Especificaciones técnicas.

Fabricados conforme a la norma **UNE-EN 13748-2**.

ESPESOR (h)	KG/M ²	M ² /PALET	KG/PALET
4	93	17,92	1.660
5	110	15,36	1.720

*Los pesos y medidas son valores orientativos.



Medidas

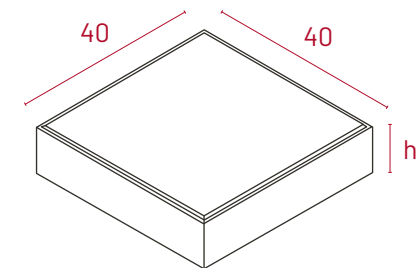

Colores disponibles

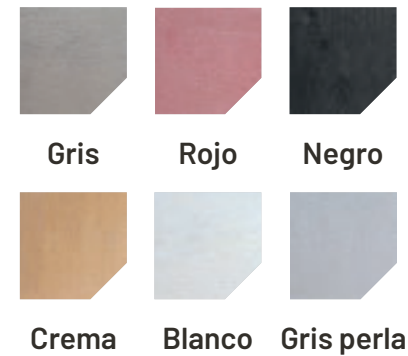

Propiedades del producto





Baldosa Hidráulica **40x40**

Granitor

Especificaciones técnicas.

Fabricados conforme a la norma **UNE-EN 13748-2**.

ESPESOR (h)	KG/M ²	M ² /PALET	KG/PALET
4	97	17,92	1.720
5	112	15,36	1.780

*Los pesos y medidas son valores orientativos.

Medidas

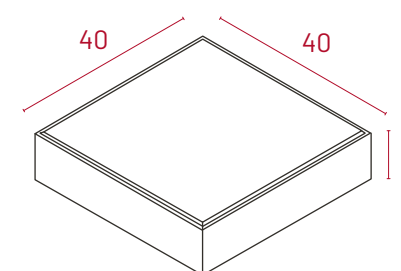

Colores disponibles

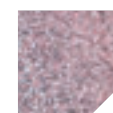

Rojo



Negro



Gris perla



Propiedades del producto



Hidrofugado



Bicapa



Sostenible



Baldosa Hidráulica 40x40

Guía (direccional)

Especificaciones técnicas.

Fabricados conforme a la norma **UNE-EN 13748-2**.

ESPESOR (h)	KG/M ²	M ² /PALET	KG/PALET
4	92	17,92	1.700
5	110	15,36	1720

*Los pesos y medidas son valores orientativos.



Medidas

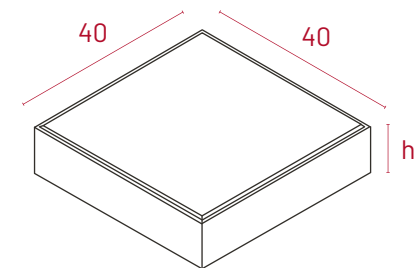

Colores disponibles

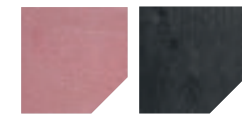

Rojo Negro

Propiedades del producto



Hidrofugado



Bicapa



Sostenible



Baldosa Hidráulica 40x40

Canto Lavado

Especificaciones técnicas.

Fabricados conforme a la norma UNE EN 1340:2004.

ESPESOR (h)	KG/M ²	M ² /PALET	KG/PALET
4	85	15,36	1.340

*Los pesos y medidas son valores orientativos.

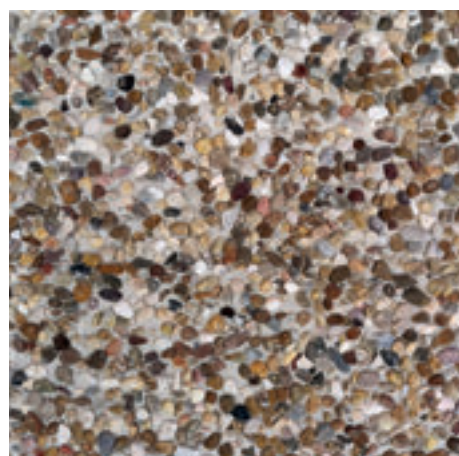

Medidas

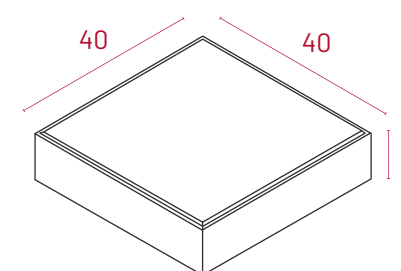

Colores disponibles



Fondo
Blanco



Fondo
Gris

Propiedades del producto



Hidrofugado



Bicapa



Sostenible





Baldosa Hidráulica

60x40

En Prefabricados Duero, somos expertos en la fabricación de baldosas hidráulicas de hormigón. Ofrecemos una amplia variedad de diseños y colores que se adaptan perfectamente a cualquier tipo de urbanización, ya sea una plaza pública o una acera.



Baldosa Hidráulica 60x40

Pétrea

Especificaciones técnicas.

Fabricados conforme a la norma **UNE-EN 13748-2**.

ESPESOR (h)	KG/M ²	M ² /PALET	KG/PALET
4	93	17,28	1.580
5	110	15,36	1.740
6	130	11,52	1.540

*Los pesos y medidas son valores orientativos.



Medidas

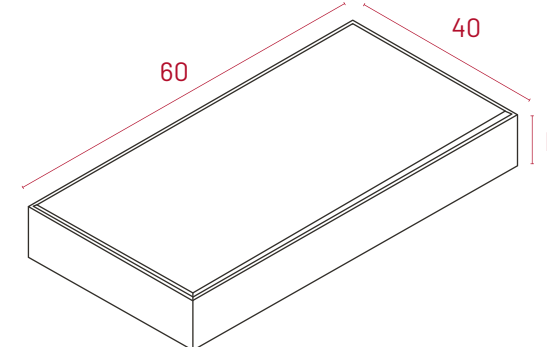

Colores disponibles

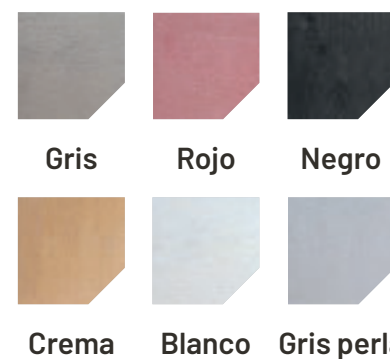

Propiedades del producto

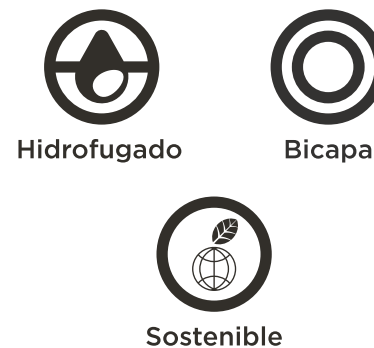



Baldosa Hidráulica **60x40**

Pizarra

Especificaciones técnicas.

Fabricados conforme a la norma **UNE-EN 13748-2**.

ESPESOR (h)	KG/M ²	M ² /PALET	KG/PALET
4	93	17,28	1.580
5	110	15,36	1.740
6	130	11,52	1.550

*Los pesos y medidas son valores orientativos.

Medidas

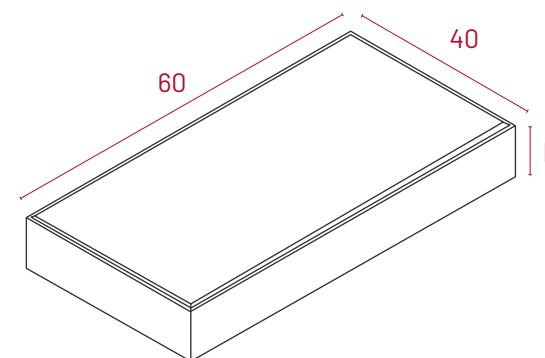

Colores disponibles

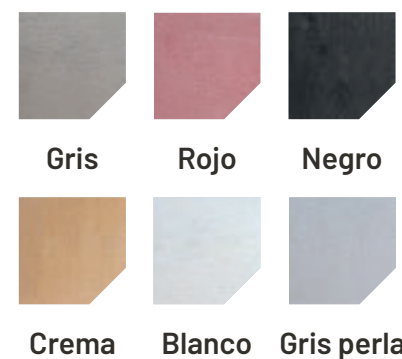

Propiedades del producto





Baldosa Hidráulica 60x40

Pergamino

Especificaciones técnicas.

Fabricados conforme a la norma **UNE-EN 13748-2**.

ESPESOR (h)	KG/M ²	M ² /PALET	KG/PALET
4	93	17,28	1.580
5	110	15,36	1.740
6	130	11,52	1.550

*Los pesos y medidas son valores orientativos.

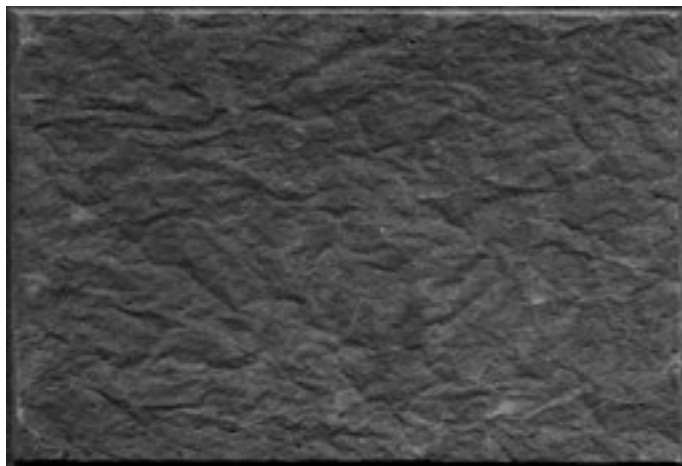

Medidas

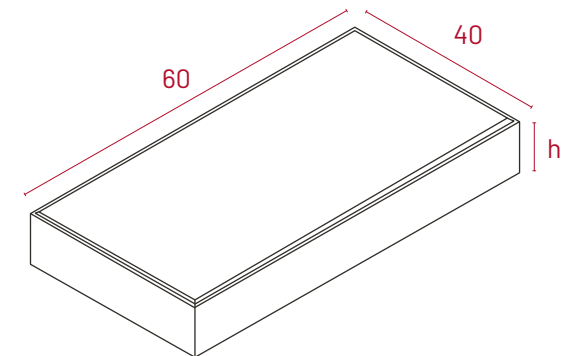

Colores disponibles

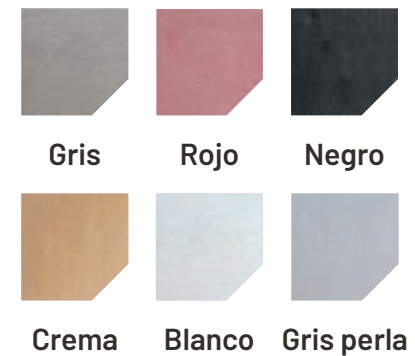

Propiedades del producto





Baldosa Hidráulica **60x40**

Granitor

Especificaciones técnicas.

Fabricados conforme a la norma **UNE-EN 13748-2**.

ESPESOR (h)	KG/M ²	M ² /PALET	KG/PALET
4	94	17,28	1.640
5	115	15,36	1.780
6	132	11,52	1.560

*Los pesos y medidas son valores orientativos.

Medidas

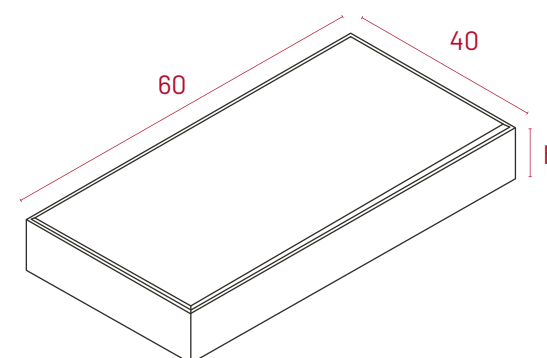

Colores disponibles



Rojo



Negro



Gris perla



Propiedades del producto



Hidrofugado



Bicapa



Sostenible





Bloques

Global **EPD**

A VERIFIED ENVIRONMENTAL DECLARATION

Bloques

TORO ESTANDAR

40x20x20	117
40x15x20	118
40x10x20	119
50x15x20	120
50x12x20	121

TORO LISO

39x19x19	123
39x14x19	124
4 Caras Lisas 39x19x19	125

TORO SPLIT

39x19x19	127
Medio 19x19x19	128
Medio Esquina 19x19x19	129
Esquina 39x19x19	130
Doble Esquina 39x19x19	131
Dos Caras Largas 39x19x19	132
Mocheta Lisa 39x19x19	133
Zuncho 39x19x19	134

PIEZAS ESPECIALES

Zuncho 40x20x20	137
Zuncho 40x15x20	138
Zuncho 39x19x19	139
Albardilla 25x20	140
Tapa de Pilar	141
Pilar Entronque	142
Pilar Esquina	143
Pilar Terminal	144
Pilar Remate	145
Ladrillo Hormigón	146



Bloques

TORO ESTÁNDAR

Los bloques de hormigón estándar son los bloques más comunes utilizados en la construcción de edificios residenciales y comerciales. Estos bloques son de forma rectangular y se utilizan principalmente para la construcción de paredes y mampostería, estando disponibles en diferentes tamaños. Los bloques estándar también son relativamente económicos y fáciles de instalar.



Bloque TORO ESTÁNDAR

40x20x20

Especificaciones técnicas.

Fabricados conforme a la norma **UNE 771-3**.

Ud./Pallet	90 Uds.
Peso Aprox Ud.	15 Kg.
Peso Aprox. Pallet	1.410 Kg.
Uso	Obra Civil
Textura	Lisa

*Los pesos y medidas son valores orientativos.



Medidas

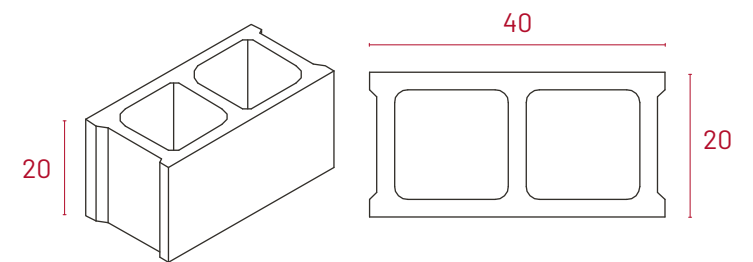

Colores disponibles



Gris

Propiedades del producto



Fuego



Sostenible



Bloque **TORO ESTÁNDAR**

40x15x20

Especificaciones técnicas.

Fabricados conforme a la norma **UNE 771-3**.

Ud./Pallet	105 Uds.
Peso Aprox Ud.	13,5 Kg.
Peso Aprox. Pallet	1.490 Kg.
Uso	Obra Civil
Textura	Lisa

*Los pesos y medidas son valores orientativos.



Medidas

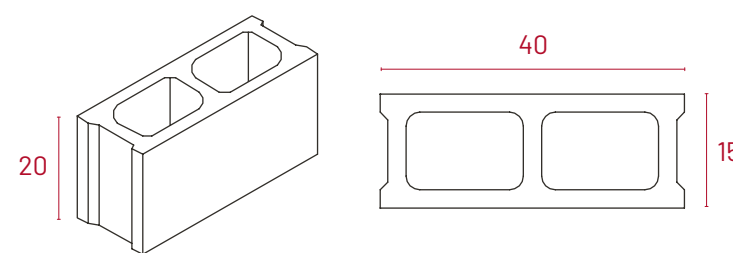

Colores disponibles



Gris

Propiedades del producto



Fuego



Sostenible



Bloque TORO ESTÁNDAR

40x10x20

Especificaciones técnicas.

Fabricados conforme a la norma **UNE 771-3**.

Ud./Pallet	150 Uds.
Peso Aprox Ud.	10 Kg.
Peso Aprox. Pallet	1.440 Kg.
Uso	Obra Civil
Textura	Lisa

*Los pesos y medidas son valores orientativos.



Medidas

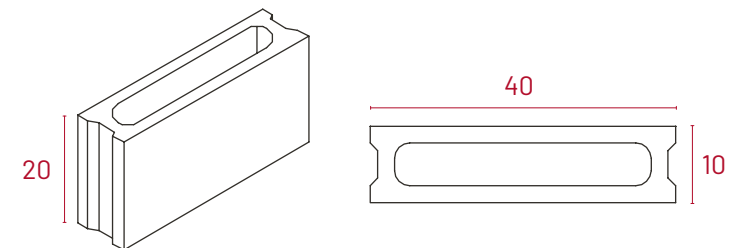

Colores disponibles

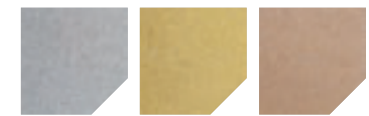

Gris Crema Tostado



Blanco Beige

Propiedades del producto



Fuego



Hidrofugado



Sostenible



Bloque **TORO ESTÁNDAR**

50x15x20

Especificaciones técnicas.

Fabricados conforme a la norma **UNE 771-3**.

Ud./Pallet	70 Uds.
Peso Aprox Ud.	16 Kg.
Peso Aprox. Pallet	1.145 Kg.
Uso	Obra Civil
Textura	Lisa

*Los pesos y medidas son valores orientativos.



Medidas

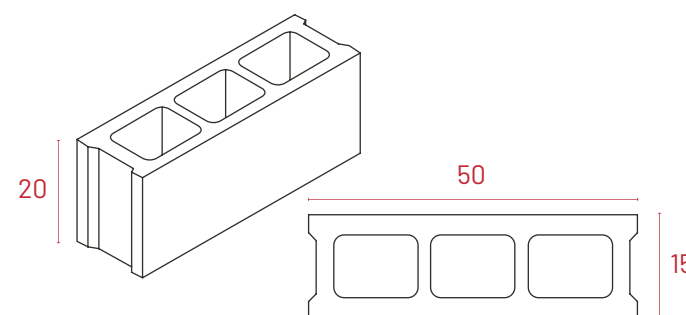

Colores disponibles



Gris

Propiedades del producto



Fuego



Sostenible



Bloque **TORO ESTÁNDAR**

50x12x20

Especificaciones técnicas.

Fabricados conforme a la norma **UNE 771-3**.

Ud./Pallet	90 Uds.
Peso Aprox Ud.	14,5 Kg.
Peso Aprox. Pallet	1.290 Kg.
Uso	Obra Civil
Textura	Lisa

*Los pesos y medidas son valores orientativos.

Medidas

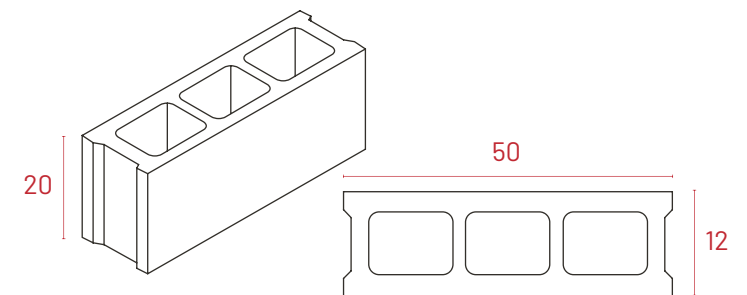

Colores disponibles



Gris

Propiedades del producto



Fuego



Sostenible





Bloques

TORO LISO

Los bloques lisos son similares a los bloques estándar en cuanto a forma y tamaño, pero difieren en su acabado superficial. A diferencia de los bloques estándar que tienen una superficie rugosa y texturizada, los bloques lisos tienen una superficie lisa y uniforme. Estos bloques se utilizan principalmente para proyectos de construcción donde la estética es una consideración importante, como en la construcción de fachadas y paredes exteriores. La superficie lisa del bloque proporciona un aspecto más moderno y limpio en comparación con los bloques estándar.



Bloque TORO LISO

39x19x19

Especificaciones técnicas.

Fabricados conforme a la norma **UNE 771-3**.

Ud./Pallet	90 Uds.
Peso Aprox Ud.	15,5 Kg.
Peso Aprox. Pallet	1.410 Kg.
Uso	Obra Civil
Textura	Lisa

*Los pesos y medidas son valores orientativos.



Medidas

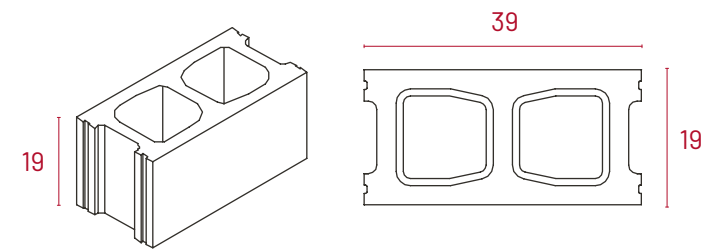

Colores disponibles



Propiedades del producto



Fuego



Sostenible



Hidrofugado



Bloque **TORO LISO**

39x14x19

Especificaciones técnicas.

Fabricados conforme a la norma **UNE 771-3**.

Ud./Pallet	105 Uds.
Peso Aprox Ud.	12,5 Kg.
Peso Aprox. Pallet	1.315 Kg.
Uso	Obra Civil
Textura	Lisa

*Los pesos y medidas son valores orientativos.



Medidas

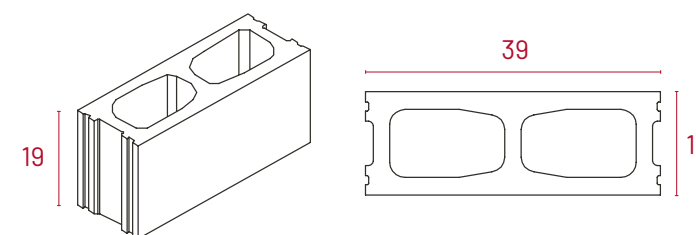

Colores disponibles

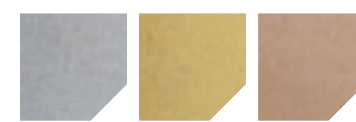

Gris Crema Tostado



Blanco Beige

Propiedades del producto



Fuego



Sostenible



Hidrofugado



Bloque TORO LISO

39x19x19 4 Caras Lisas

Especificaciones técnicas.

Fabricados conforme a la norma **UNE 771-3:2001**.

Ud./Pallet	70 Uds.
Peso Aprox Ud.	15 Kg.
Peso Aprox. Pallet	1.080 Kg.
Uso	Obra Civil
Textura	Lisa

*Los pesos y medidas son valores orientativos.



Medidas

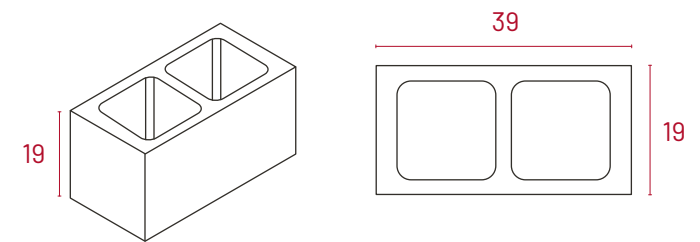

Colores disponibles



Propiedades del producto



Fuego



Sostenible



Hidrofugado



Bloques

TORO SPLIT

Los bloques split son bloques de hormigón que se caracterizan por tener una superficie con textura áspera y natural que se asemeja a la piedra natural. Estos bloques se utilizan principalmente para proyectos de construcción que requieren un aspecto más rústico y natural. Los bloques split se fabrican de la misma manera que los bloques estándar, pero la superficie del molde se trata de manera diferente para lograr la textura áspera y natural. Después de que la mezcla de hormigón se vierte en el molde, se utiliza un proceso de desmoldeo especial para exponer la textura de la superficie del bloque.



Bloque **TORO SPLIT**

39x19x19

Especificaciones técnicas.

Fabricados conforme a la norma **UNE 771-3:2001**.

Ud./Pallet	75 Uds.
Peso Aprox Ud.	18 Kg.
Peso Aprox. Pallet	1.360 Kg.
Uso	Obra Civil
Textura	Rugosa a una cara

*Los pesos y medidas son valores orientativos.

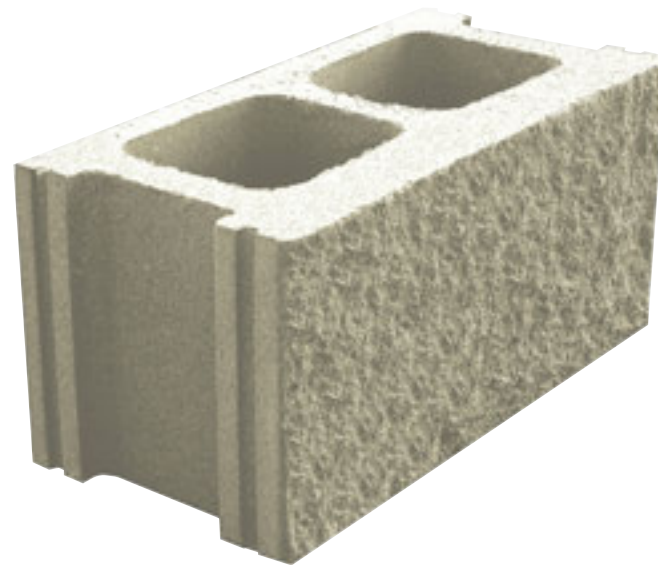

Medidas

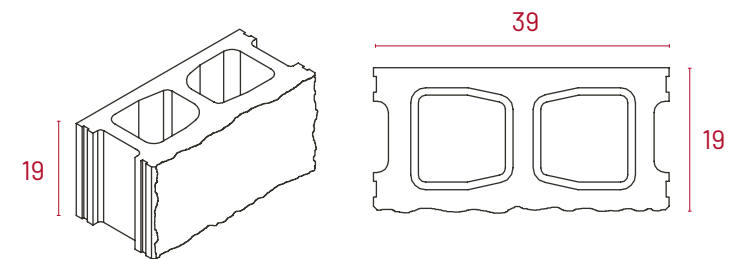

Colores disponibles



Gris Crema Tostado



Blanco Beige

Propiedades del producto



Fuego



Hidrofugado



Sostenible



Bloque **TORO SPLIT**

Medio 19x19x19

Especificaciones técnicas.

Fabricados conforme a la norma **UNE 771-3**.

Ud./Pallet	150 Uds.
Peso Aprox Ud.	10 Kg.
Peso Aprox. Pallet	1.500 Kg.
Uso	Obra Civil
Textura	Rugosa a una cara

*Los pesos y medidas son valores orientativos.



Medidas

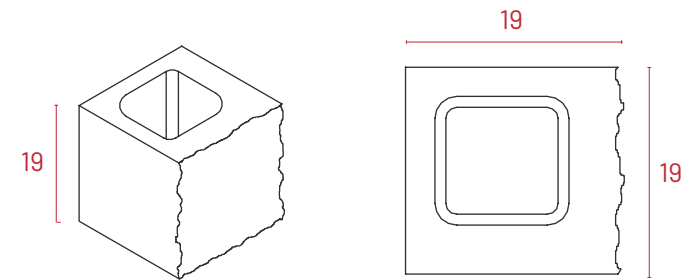

Colores disponibles



Gris Crema Tostado



Blanco Beige

Propiedades del producto



Fuego



Hidrofugado



Sostenible



Bloque TORO SPLIT

Medio Esquina 19x19x19

Especificaciones técnicas.

Fabricados conforme a la norma **UNE 771-3**.

Ud./Pallet	150 Uds.
Peso Aprox Ud.	10 Kg.
Peso Aprox. Pallet	1.500 Kg.
Uso	Obra Civil
Textura	Rugosa a dos caras

*Los pesos y medidas son valores orientativos.



Medidas

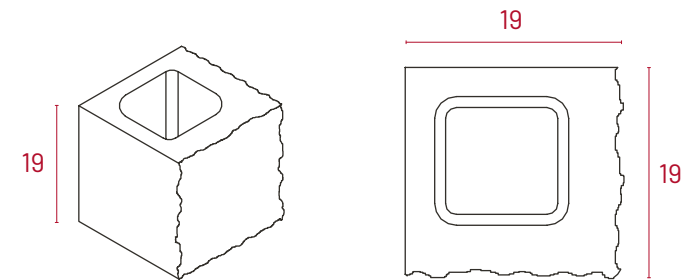

Colores disponibles

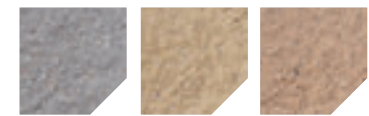

Gris Crema Tostado



Blanco Beige

Propiedades del producto



Fuego



Hidrofugado



Sostenible



Bloque **TORO SPLIT**

Esquina **39x19x19**

Especificaciones técnicas.

Fabricados conforme a la norma **UNE 771-3**.

Ud./Pallet	75 Uds.
Peso Aprox Ud.	17,5 Kg.
Peso Aprox. Pallet	1.340 Kg.
Uso	Obra Civil
Textura	Rugosa a dos caras

*Los pesos y medidas son valores orientativos.



Medidas

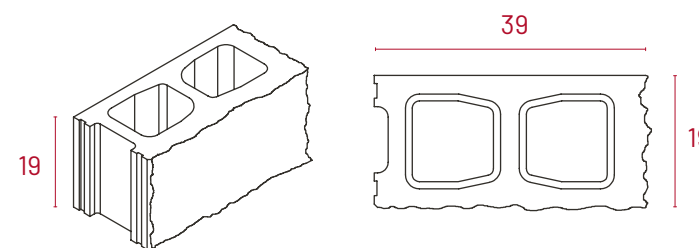

Colores disponibles



Gris Crema Tostado



Blanco Beige

Propiedades del producto



Fuego



Hidrofugado



Sostenible



Bloque **TORO SPLIT**

Doble Esquina **39x19x19**

Especificaciones técnicas.

Fabricados conforme a la norma **UNE 771-3**.

Ud./Pallet	75 Uds.
Peso Aprox Ud.	19 Kg.
Peso Aprox. Pallet	1.440 Kg.
Uso	Obra Civil
Textura	Rugosa a tres caras

*Los pesos y medidas son valores orientativos.

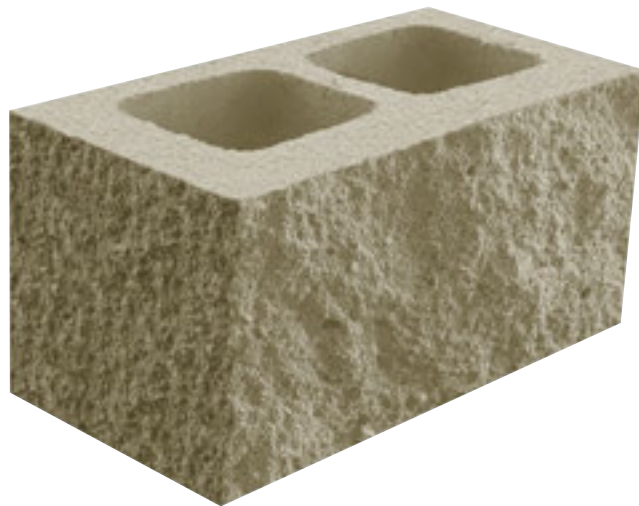

Medidas

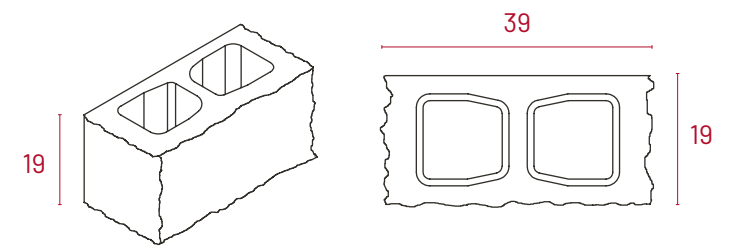

Colores disponibles

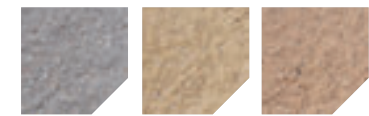

Gris Crema Tostado



Blanco Beige

Propiedades del producto



Fuego



Hidrofugado



Sostenible



Bloque **TORO SPLIT**

Dos Caras Largas **39x19x19**

Especificaciones técnicas.

Fabricados conforme a la norma **UNE 771-3**.

Ud./Pallet	75 Uds.
Peso Aprox Ud.	20 Kg.
Peso Aprox. Pallet	1.550 Kg.
Uso	Obra Civil
Textura	Rugosa a dos caras

*Los pesos y medidas son valores orientativos.

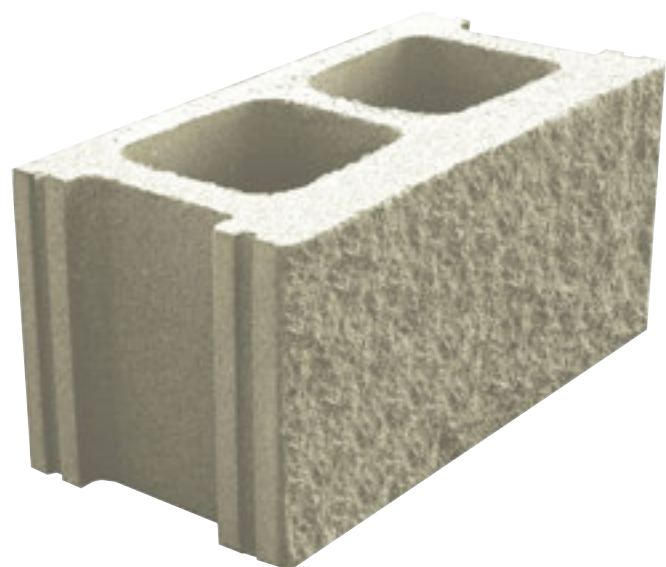

Medidas

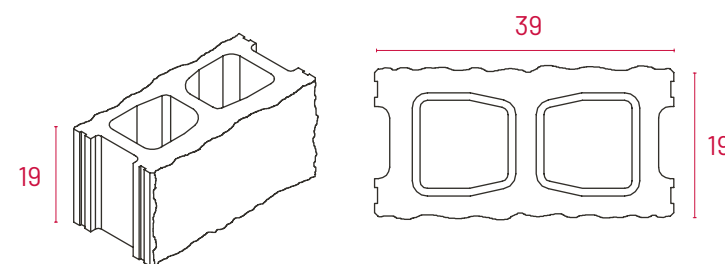

Colores disponibles



Gris Crema Tostado



Blanco Beige

Propiedades del producto



Fuego



Hidrofugado



Sostenible



Bloque TORO SPLIT

Mocheta Lisa 39x19x19

Especificaciones técnicas.

Fabricados conforme a la norma **UNE 771-3**.

Ud./Pallet	75 Uds.
Peso Aprox Ud.	20 Kg.
Peso Aprox. Pallet	1.500 Kg.
Uso	Obra Civil
Textura	Rugosa a una cara

*Los pesos y medidas son valores orientativos.



Medidas

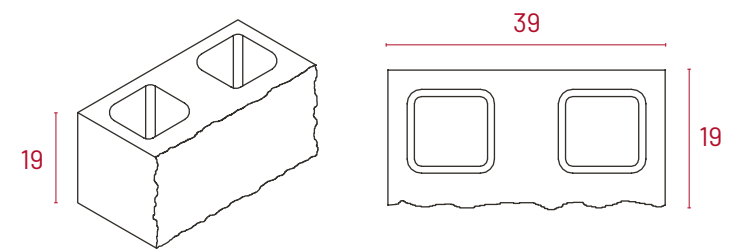

Colores disponibles



Propiedades del producto



Fuego



Hidrofugado



Sostenible



Bloque **TORO SPLIT**

Zuncho **39x19x19**

Especificaciones técnicas.

Fabricados conforme a la norma **UNE 771-3**.

Ud./Pallet	75 Uds.
Peso Aprox Ud.	22,5 Kg.
Peso Aprox. Pallet	1.700 Kg.
Uso	Obra Civil
Textura	Rugosa a una cara

*Los pesos y medidas son valores orientativos.

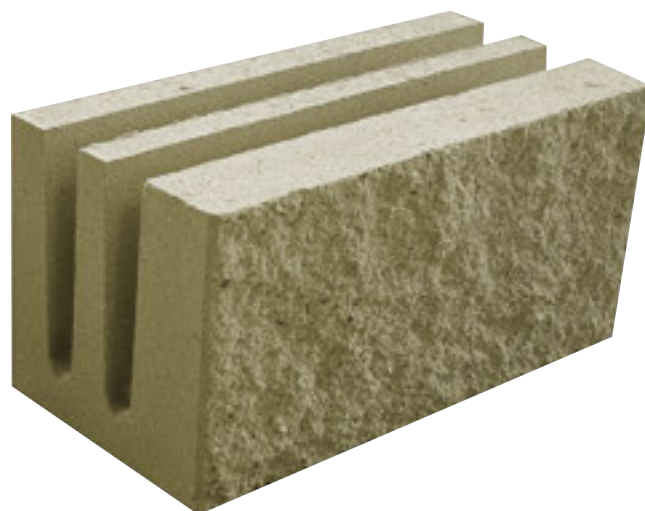

Medidas

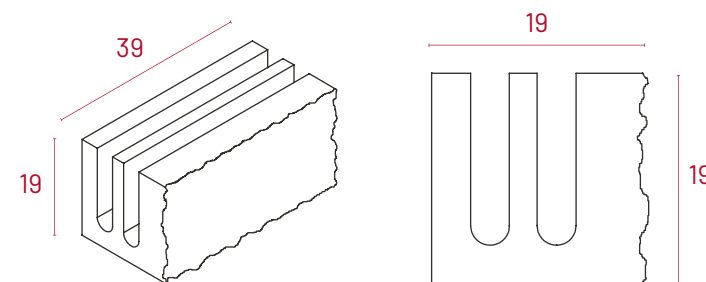

Colores disponibles



Gris Crema Tostado



Blanco Beige

Propiedades del producto



Fuego



Hidrofugado



Sostenible





Bloques

PIEZAS ESPECIALES

Las piezas especiales de hormigón prefabricado son elementos clave en la construcción moderna, ofreciendo soluciones eficientes y versátiles para una variedad de proyectos. Estas piezas, fabricadas en condiciones controladas, presentan características únicas que las hacen ideales para aplicaciones específicas en edificación e infraestructura.



Piezas Especiales

Zuncho 40x20x20

Especificaciones técnicas.

Fabricados conforme a la norma **UNE 771-3**.

Ud./Pallet	75 Uds.
Peso Aprox Ud.	20 Kg.
Peso Aprox. Pallet	1.560 Kg.
Uso	Obra Civil
Textura	Lisa

*Los pesos y medidas son valores orientativos.

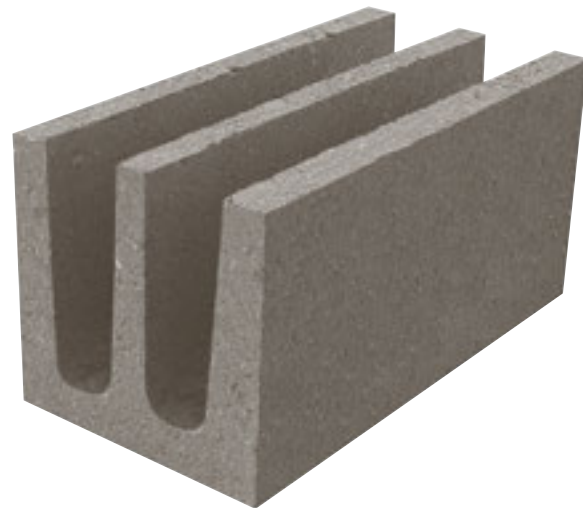

Medidas

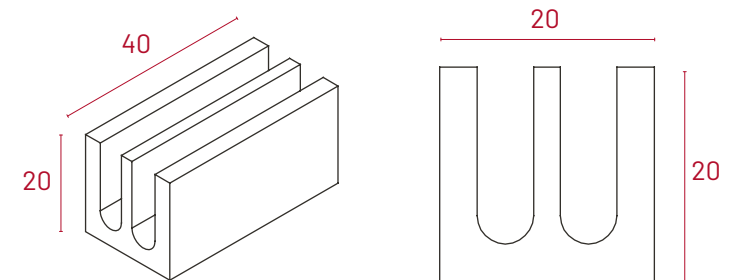

Colores disponibles



Gris

Propiedades del producto



Fuego



Sostenible



Piezas Especiales

Zuncho 40x15x20

Especificaciones técnicas.

Fabricados conforme a la norma **UNE 771-3**.

Ud./Pallet	105 Uds.
Peso Aprox Ud.	14 Kg.
Peso Aprox. Pallet	1.480 Kg.
Uso	Obra Civil
Textura	Lisa

*Los pesos y medidas son valores orientativos.

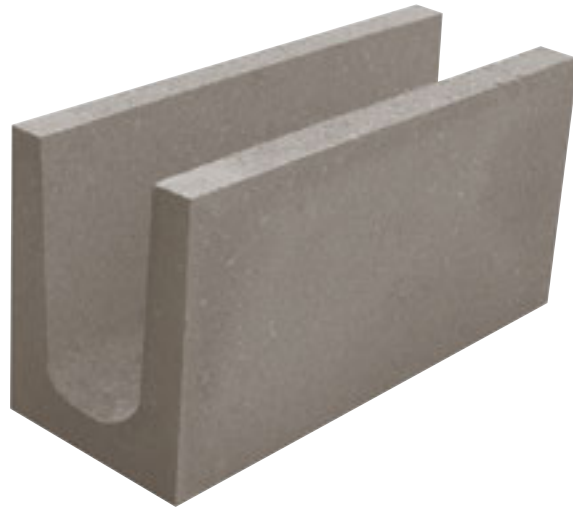

Medidas

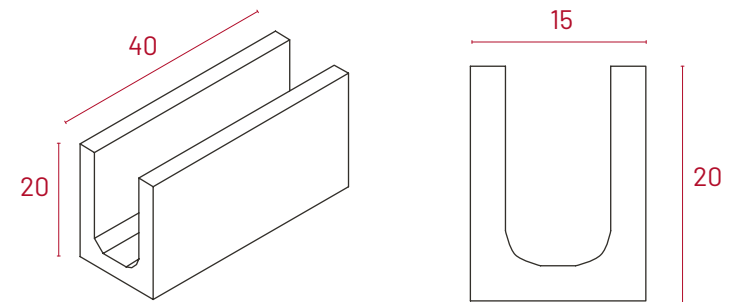

Colores disponibles



Gris

Propiedades del producto



Fuego



Sostenible



Piezas Especiales

Zuncho 39x19x19

Especificaciones técnicas.

Fabricados conforme a la norma **UNE 771-3**.

Ud./Pallet	75 Uds.
Peso Aprox Ud.	12 Kg.
Peso Aprox. Pallet	920 Kg.
Uso	Obra Civil
Textura	Lisa

*Los pesos y medidas son valores orientativos.

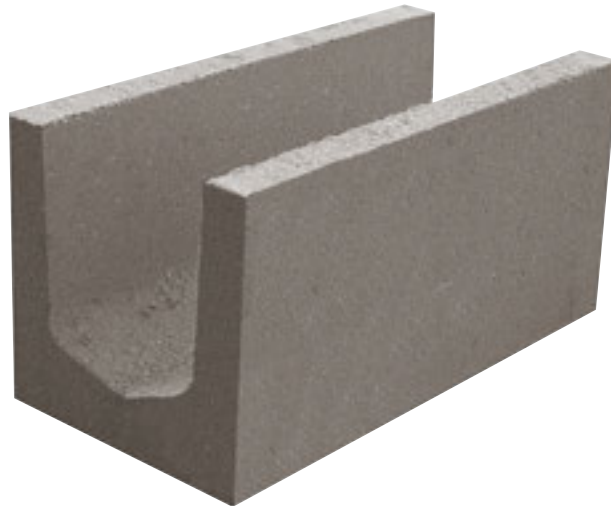

Medidas

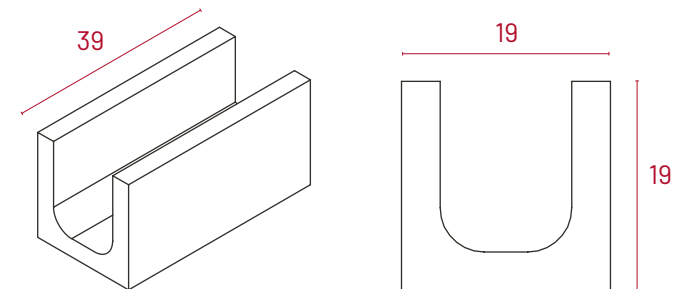

Colores disponibles



Propiedades del producto



Fuego



Hidrofugado



Sostenible



Piezas Especiales

Albardilla 25x20

Especificaciones técnicas.

Fabricados conforme a la norma **UNE 771-3**.

Ud./Pallet	144 Uds.
Peso Aprox Ud.	5,5 Kg.
Peso Aprox. Pallet	840 Kg.
Uso	Obra Civil
Textura	Lisa

*Los pesos y medidas son valores orientativos.



Medidas

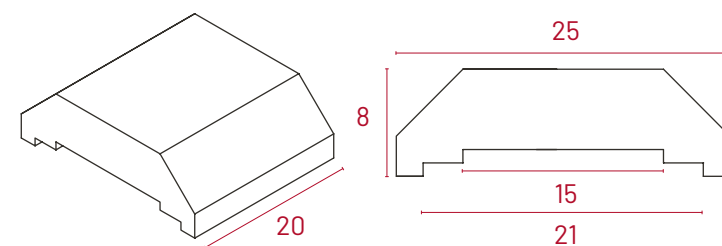

Colores disponibles



Gris Crema Tostado



Blanco Beige

Propiedades del producto



Fuego



Hidrofugado



Sostenible



Piezas Especiales

Tapa de Pilar 35x35 45x45

Especificaciones técnicas.

Fabricados conforme a la norma **UNE-EN 771-3**.

Medidas	35x35	45x45
LE	35	45
LI	31,5	41,5
Peso aproxUd./kg	12	23

*Los pesos y medidas son valores orientativos.



Medidas

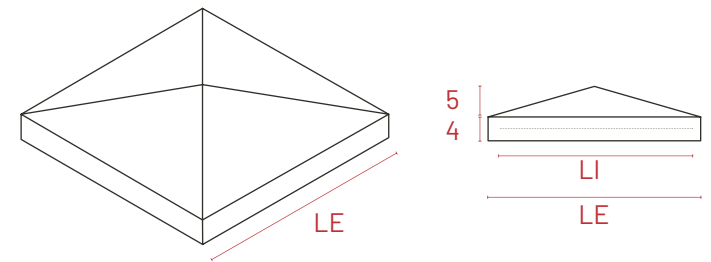

Colores disponibles



Gris Crema Tostado



Blanco Beige

Propiedades del producto



Fuego



Hidrofugado



Sostenible



Piezas Especiales

Pilar Entronque 30x30x19

Especificaciones técnicas.

Fabricados conforme a la norma **UNE 771-3**.

Ud./Pallet	60 Uds.
Peso Aprox Ud.	19 Kg.
Peso Aprox. Pallet	1.140 Kg.
Uso	Obra Civil
Textura	Lisa

*Los pesos y medidas son valores orientativos.



Medidas

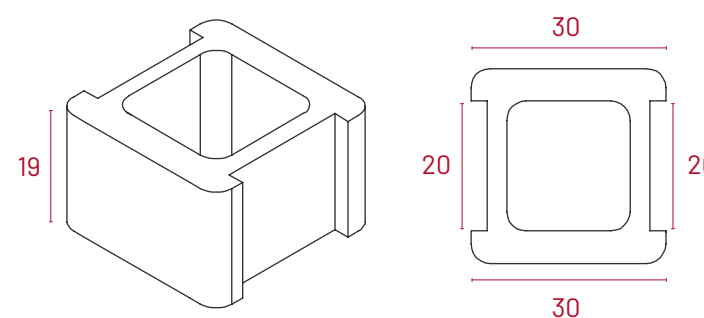

Colores disponibles



Gris Crema Tostado



Blanco Beige

Propiedades del producto



Fuego



Hidrofugado



Sostenible



Piezas Especiales

Pilar Esquina 30x30x19

Especificaciones técnicas.

Fabricados conforme a la norma **UNE 771-3**.

Ud./Pallet	60 Uds.
Peso Aprox Ud.	19 Kg.
Peso Aprox. Pallet	1.140 Kg.
Uso	Obra Civil
Textura	Lisa

*Los pesos y medidas son valores orientativos.



Medidas

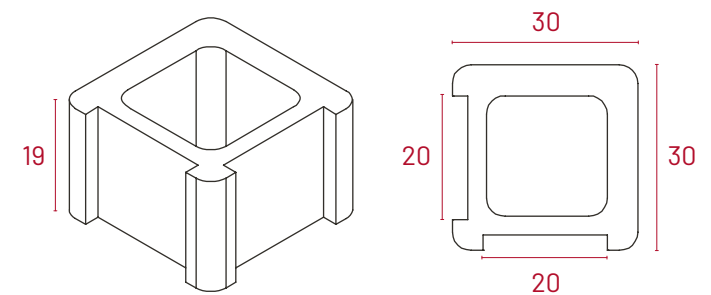

Colores disponibles



Gris Crema Tostado



Blanco Beige

Propiedades del producto



Fuego



Hidrofugado



Sostenible



Piezas Especiales

Pilar Terminal 30x30x19

Especificaciones técnicas.

Fabricados conforme a la norma **UNE 771-3**.

Ud./Pallet	60 Uds.
Peso Aprox Ud.	20 Kg.
Peso Aprox. Pallet	1.200 Kg.
Uso	Obra Civil
Textura	Lisa

*Los pesos y medidas son valores orientativos.



Medidas

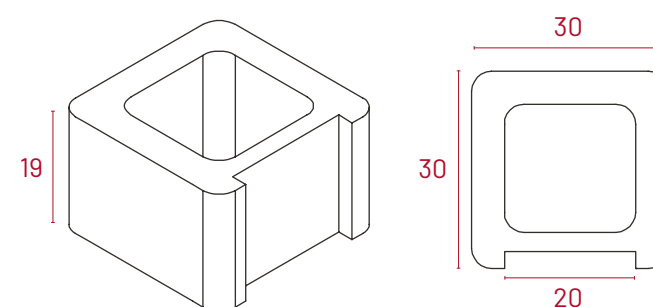

Colores disponibles



Gris Crema Tostado



Blanco Beige

Propiedades del producto



Fuego



Hidrofugado



Sostenible



Piezas Especiales

Pilar Remate 30x30x19

Especificaciones técnicas.

Fabricados conforme a la norma **UNE 771-3**.

Ud./Pallet	60 Uds.
Peso Aprox Ud.	21 Kg.
Peso Aprox. Pallet	1.320 Kg.
Uso	Obra Civil
Textura	Lisa

*Los pesos y medidas son valores orientativos.



Medidas

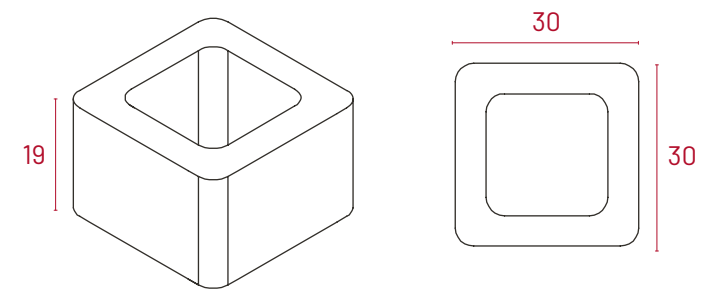

Colores disponibles



Gris Crema Tostado

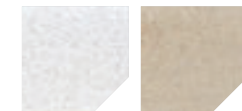

Blanco Beige

Propiedades del producto



Fuego



Hidrofugado



Sostenible



Piezas Especiales

Ladrillo Hormigón 25x11,5x10

Especificaciones técnicas.

Fabricados conforme a la norma **UNE 771-3**.

Ud./Pallet	216 Uds.
Peso Aprox Ud.	3,5 Kg.
Peso Aprox. Pallet	810 Kg.
Uso	Obra Civil
Textura	Lisa

*Los pesos y medidas son valores orientativos.

Medidas

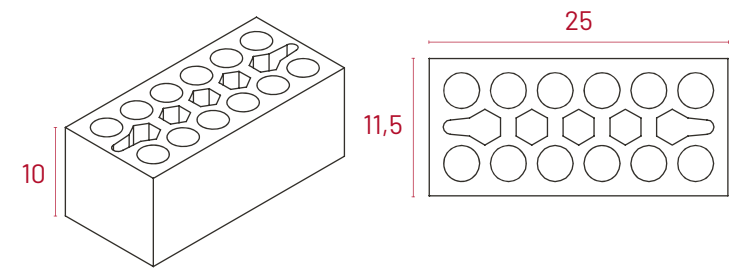

Colores disponibles



Gris

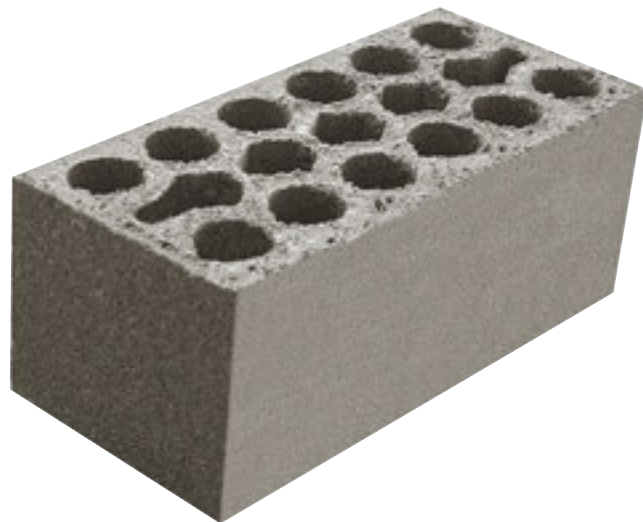

Propiedades del producto



Acústico



Fuego



Sostenible

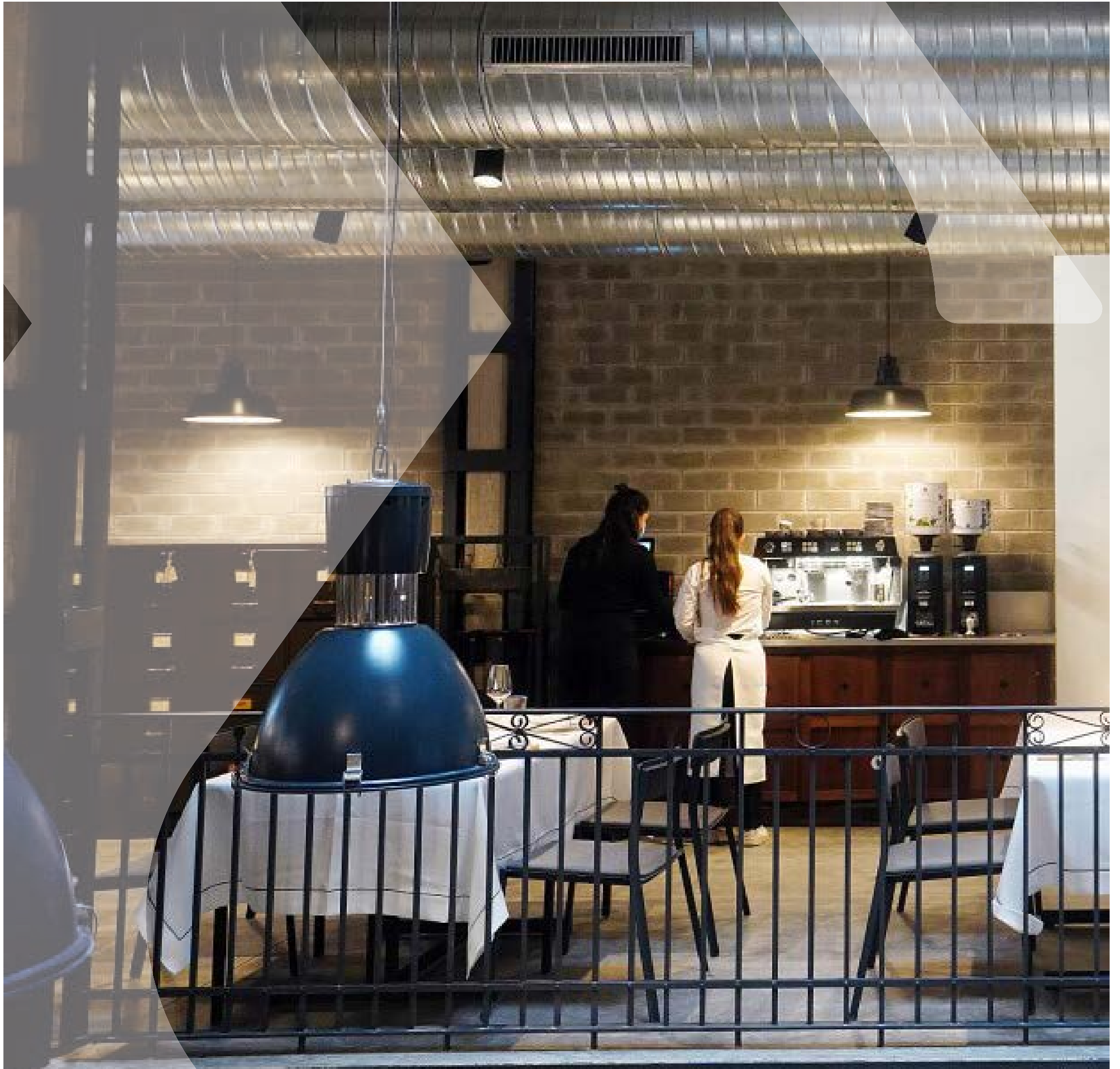



Bovedillas y Casetones

GlobalEPD

A VERIFIED ENVIRONMENTAL DECLARATION

Bovedillas y Casetones

BOVEDILLAS ZAMORA

58x17x20	151
58x20x20	152
58x22x20	153
58x25x20	154
58x27x20	156
58x30x20	157
58x22x20 Ciega	158
58x25x15 Ciega	159
58x27x20 Ciega	160
58x25x20 In situ	161
58x30x20 In situ	162
70x30x20 In situ	163

CASETONES ZAMORA

60x25x20	165
70x23x25	166
70x23x22	167
70x23x30	168



Bovedillas y Casetones

BOVEDILLAS

Diseñados especialmente para el aligeramiento de forjados unidireccionales o reticulares. Las bovedillas de hormigón son la solución ideal para conseguir una estructura de gran resistencia y con una gran durabilidad. En Prefabricados Duero, somos expertos en su fabricación, y ofrecemos una amplia variedad de medidas y resistencias para adaptarnos a las necesidades de cada proyecto.



Bovedillas ZAMORA

58x17x20

Especificaciones técnicas.

Fabricados conforme a la norma **UNE-EN 15037-2**.

Ud./Pallet	60 Uds.
Peso Aprox Ud.	16,5 Kg.
Peso Aprox. Pallet	1.000 Kg.
Uso	Obra Civil
Textura	Lisa

*Los pesos y medidas son valores orientativos.



Medidas

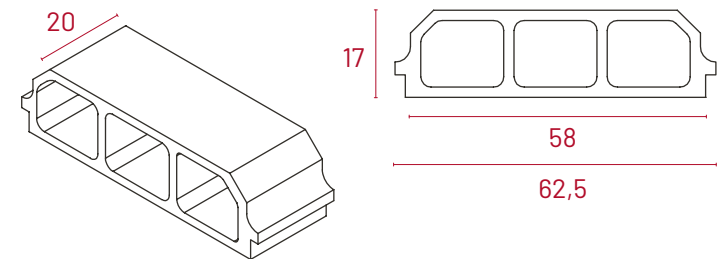

Colores disponibles



Gris

Propiedades del producto



Fuego



Sostenible



Bovedillas **ZAMORA**

58x20x20

Especificaciones técnicas.

Fabricados conforme a la norma **UNE-EN 15037-2**.

Ud./Pallet	50 Uds.
Peso Aprox Ud.	17,5 Kg.
Peso Aprox. Pallet	880 Kg.
Uso	Obra Civil
Textura	Lisa

*Los pesos y medidas son valores orientativos.

Medidas

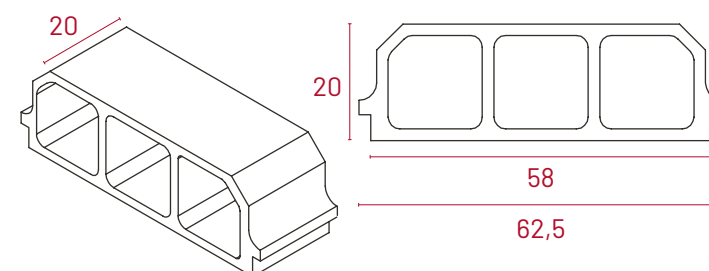

Colores disponibles



Gris

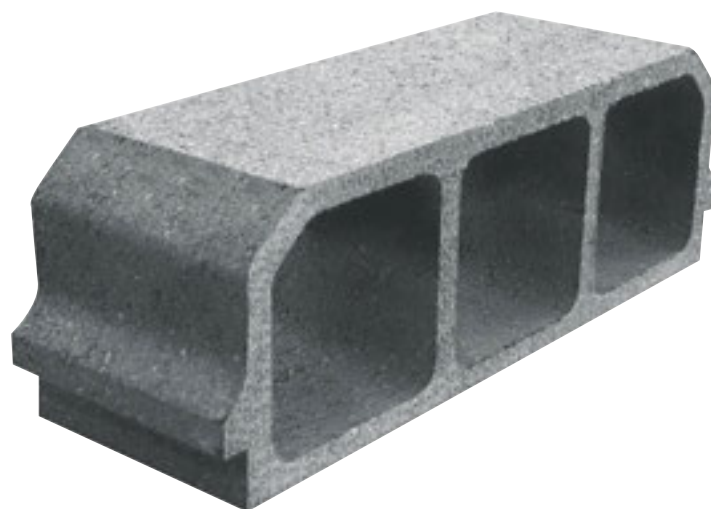

Propiedades del producto



Fuego



Sostenible

Bovedillas **ZAMORA**

58x22x20**Especificaciones técnicas.**Fabricados conforme a la norma **UNE-EN 15037-2**.

Ud./Pallet	50 Uds.
Peso Aprox Ud.	18 Kg.
Peso Aprox. Pallet	940 Kg.
Uso	Obra Civil
Textura	Lisa

*Los pesos y medidas son valores orientativos.

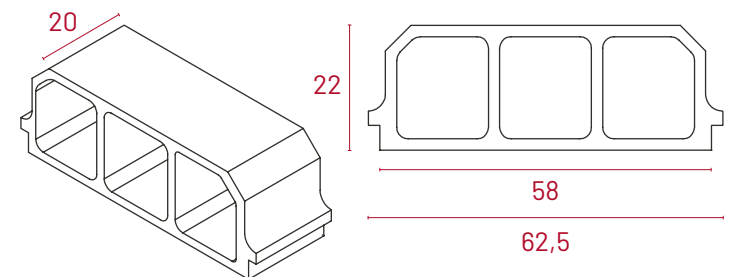
**Medidas****Colores disponibles**

Gris

Propiedades del producto

Fuego



Sostenible



Bovedillas **ZAMORA**

58x25x20

Especificaciones técnicas.

Fabricados conforme a la norma **UNE-EN 15037-2**.

Ud./Pallet	40 Uds.
Peso Aprox Ud.	19 Kg.
Peso Aprox. Pallet	780 Kg.
Uso	Obra Civil
Textura	Lisa

*Los pesos y medidas son valores orientativos.

Medidas

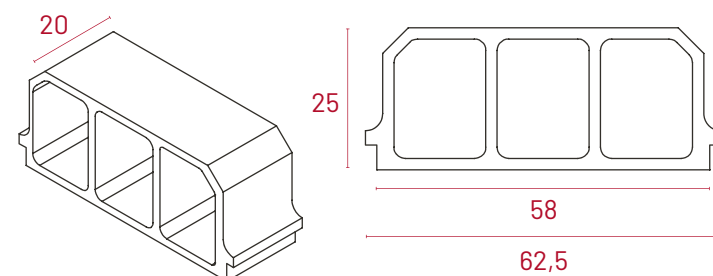

Colores disponibles



Gris

Propiedades del producto



Fuego



Sostenible







Bovedillas **ZAMORA**

58x27x20

Especificaciones técnicas.

Fabricados conforme a la norma **UNE-EN 15037-2**.

Ud./Pallet	40 Uds.
Peso Aprox Ud.	20 Kg.
Peso Aprox. Pallet	810 Kg.
Uso	Obra Civil
Textura	Lisa

*Los pesos y medidas son valores orientativos.

Medidas

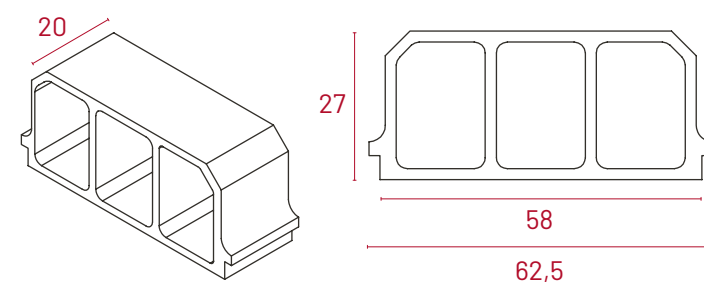

Colores disponibles



Gris



Propiedades del producto



Fuego



Sostenible

Bovedillas **ZAMORA**

58x30x20

Especificaciones técnicas.

Fabricados conforme a la norma **UNE-EN 15037-2**.

Ud./Pallet	40 Uds.
Peso Aprox Ud.	21 Kg.
Peso Aprox. Pallet	850 Kg.
Uso	Obra Civil
Textura	Lisa

*Los pesos y medidas son valores orientativos.

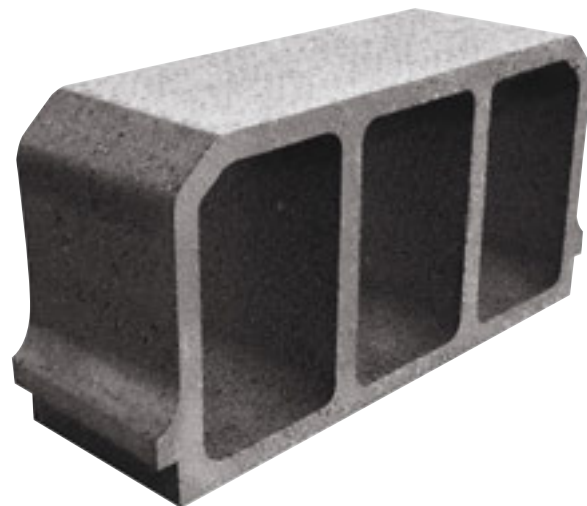

Medidas

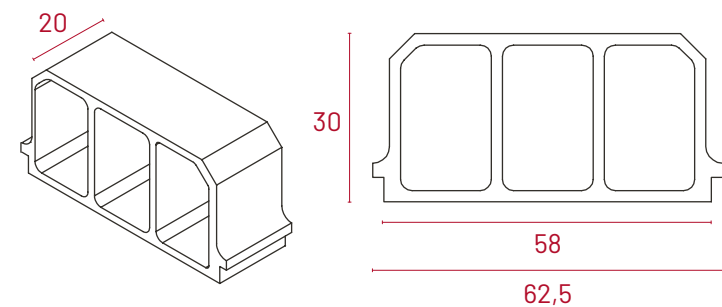

Colores disponibles



Gris

Propiedades del producto



Fuego



Sostenible



Bovedillas **ZAMORA**

58x22x20 **Ciega**

Especificaciones técnicas.

Fabricados conforme a la norma **UNE-EN 15037-2**.

Ud./Pallet	50 Uds.
Peso Aprox Ud.	21,5 Kg.
Peso Aprox. Pallet	1.080 Kg.
Uso	Obra Civil
Textura	Lisa

*Los pesos y medidas son valores orientativos.



Medidas

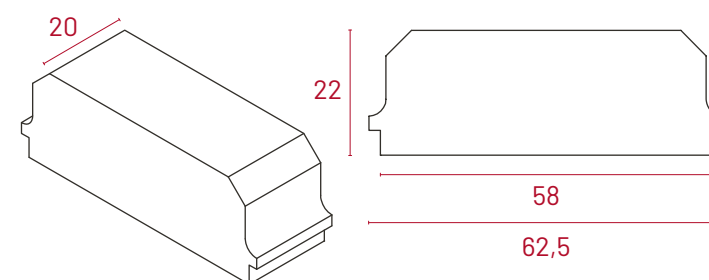

Colores disponibles



Gris

Propiedades del producto



Fuego



Sostenible

Bovedillas **ZAMORA**

58x25x15 **Ciega**

Especificaciones técnicas.

Fabricados conforme a la norma **UNE-EN 15037-2**.

Ud./Pallet	48 Uds.
Peso Aprox Ud.	17,8 Kg.
Peso Aprox. Pallet	875 Kg.
Uso	Obra Civil
Textura	Lisa

*Los pesos y medidas son valores orientativos.



Medidas

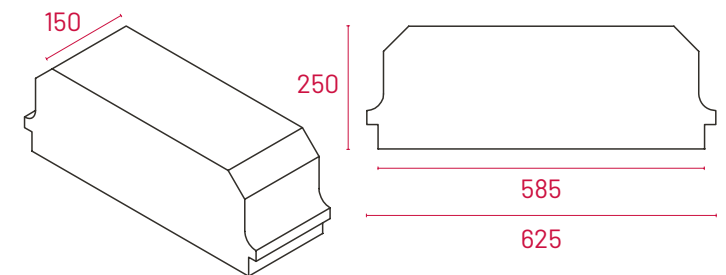

Colores disponibles



Gris

Propiedades del producto



Fuego



Sostenible



Bovedillas **ZAMORA**

58x27x20 **Ciega**

Especificaciones técnicas.

Fabricados conforme a la norma **UNE-EN 15037-2**.

Ud./Pallet	40 Uds.
Peso Aprox Ud.	23,5 Kg.
Peso Aprox. Pallet	960 Kg.
Uso	Obra Civil
Textura	Lisa

*Los pesos y medidas son valores orientativos.



Medidas

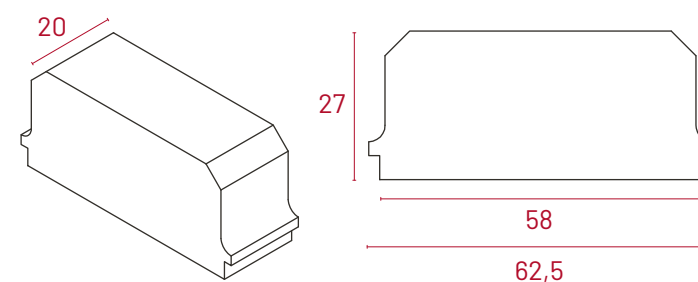

Colores disponibles



Gris

Propiedades del producto



Fuego



Sostenible

Bovedillas **ZAMORA**

58x25x20 **In Situ**

Especificaciones técnicas.

Fabricados conforme a la norma **UNE-EN 15037-2**.

Ud./Pallet	40 Uds.
Peso Aprox Ud.	18,5 Kg.
Peso Aprox. Pallet	755 Kg.
Uso	Obra Civil
Textura	Lisa

*Los pesos y medidas son valores orientativos.

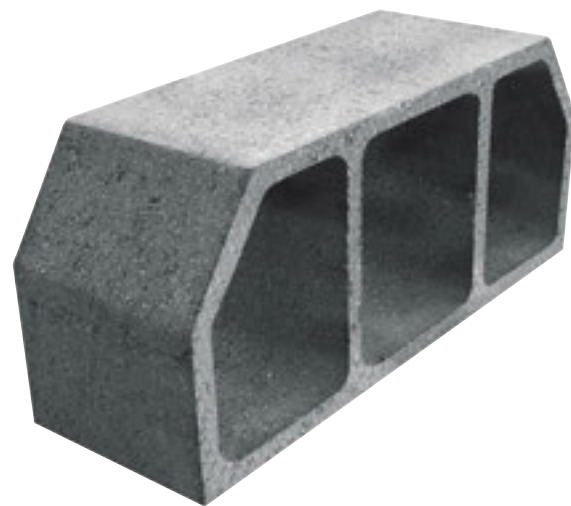

Medidas

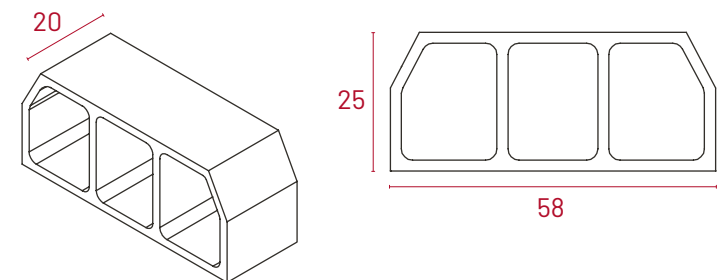

Colores disponibles



Gris

Propiedades del producto



Fuego



Sostenible



Bovedillas **ZAMORA**

58x30x20 **In Situ**

Especificaciones técnicas.

Fabricados conforme a la norma **UNE-EN 15037-2**.

Ud./Pallet	30 Uds.
Peso Aprox Ud.	20 Kg.
Peso Aprox. Pallet	630 Kg.
Uso	Obra Civil
Textura	Lisa

*Los pesos y medidas son valores orientativos.

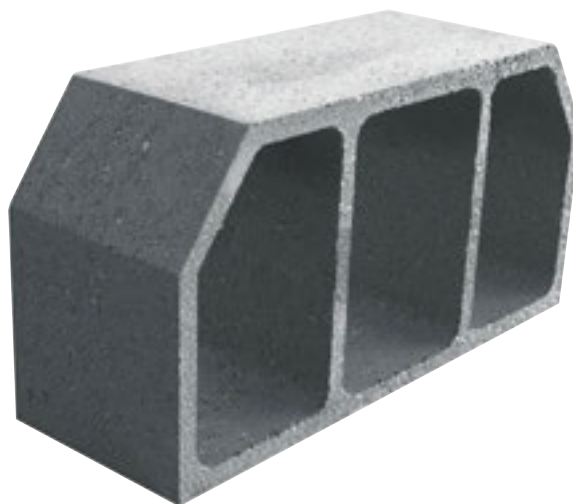

Medidas

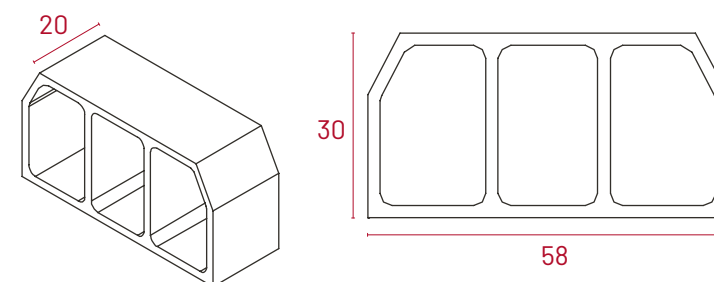

Colores disponibles



Gris

Propiedades del producto



Fuego



Sostenible

Bovedillas **ZAMORA**

70x30x20 **In Situ**

Especificaciones técnicas.

Fabricados conforme a la norma **UNE-EN 15037-2**.

Ud./Pallet	30 Uds.
Peso Aprox Ud.	23 Kg.
Peso Aprox. Pallet	720 Kg.
Uso	Obra Civil
Textura	Lisa

*Los pesos y medidas son valores orientativos.

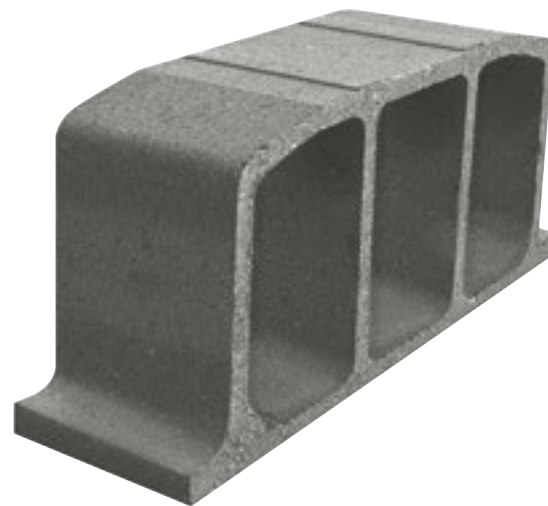

Medidas

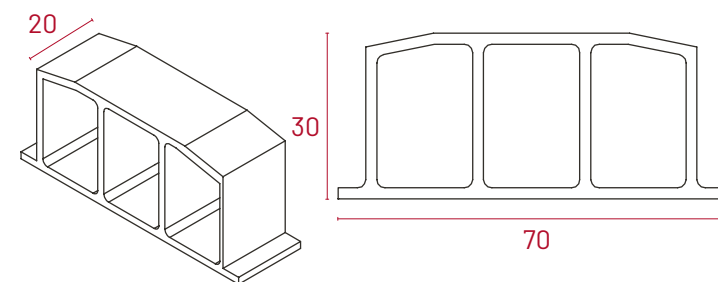

Colores disponibles



Gris

Propiedades del producto



Fuego



Sostenible



Bovedillas y Casetones

CASETONES

Los casetones de hormigón se utilizan principalmente en la construcción de forjados aligerados, techos y cubiertas, ya que permiten reducir el peso propio de la estructura, mejorando la eficiencia energética y reduciendo el coste de la construcción. Nuestros casetones de hormigón son ideales para la construcción de edificios de gran altura, ya que gracias a su ligereza y resistencia permiten reducir el peso total de la estructura, al tiempo que mejoran la capacidad de aislamiento térmico y acústico.



Casetones ZAMORA

60x25x20

Especificaciones técnicas.

Ud./Pallet	40 Uds.
Peso Aprox Ud.	24 Kg.
Peso Aprox. Pallet	965 Kg.
Uso	Obra Civil
Textura	Lisa

*Los pesos y medidas son valores orientativos.



Medidas

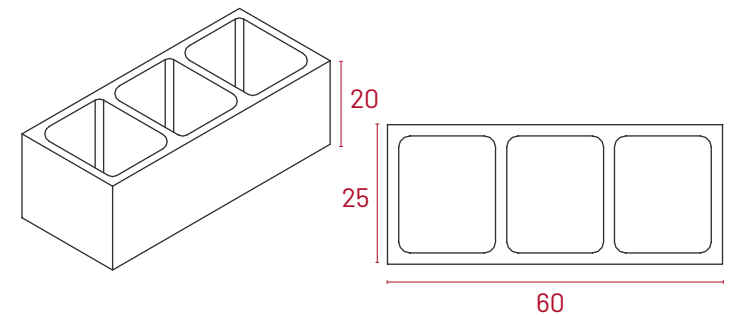

Colores disponibles



Gris

Propiedades del producto



Fuego



Sostenible



Casetones **ZAMORA**

70x23x25

Especificaciones técnicas.

Ud./Pallet	32 Uds.
Peso Aprox Ud.	37 Kg.
Peso Aprox. Pallet	1.195 Kg.
Uso	Obra Civil
Textura	Lisa

*Los pesos y medidas son valores orientativos.

Medidas

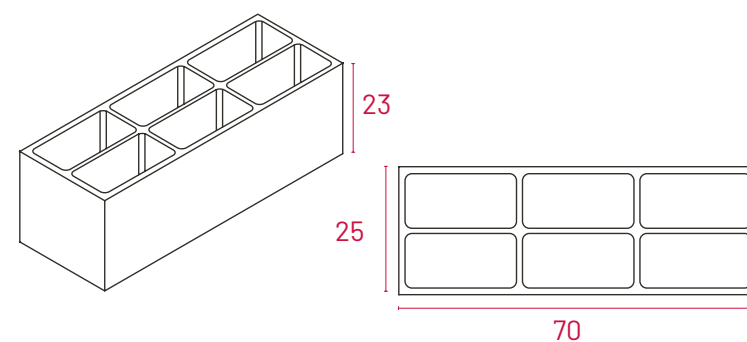

Colores disponibles



Gris

Propiedades del producto



Fuego



Sostenible





Casetones ZAMORA

70x23x22

Especificaciones técnicas.

Ud./Pallet	40 Uds.
Peso Aprox Ud.	30 Kg.
Peso Aprox. Pallet	1.215 Kg.
Uso	Obra Civil
Textura	Lisa

*Los pesos y medidas son valores orientativos.

Medidas

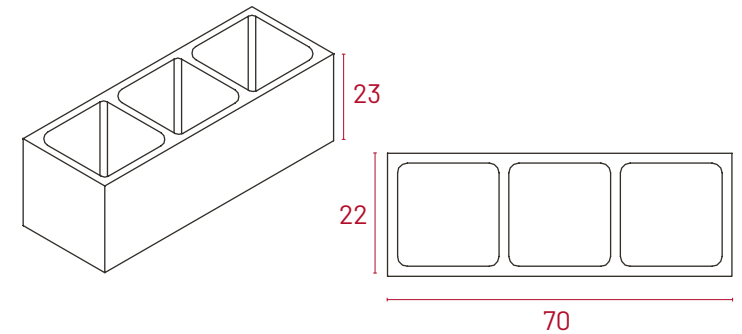

Colores disponibles



Gris



Propiedades del producto



Fuego



Sostenible



Casetones **ZAMORA**

70x23x30

Especificaciones técnicas.

Ud./Pallet	24 Uds.
Peso Aprox Ud.	41 Kg.
Peso Aprox. Pallet	1.000 Kg.
Uso	Obra Civil
Textura	Lisa

*Los pesos y medidas son valores orientativos.

Medidas

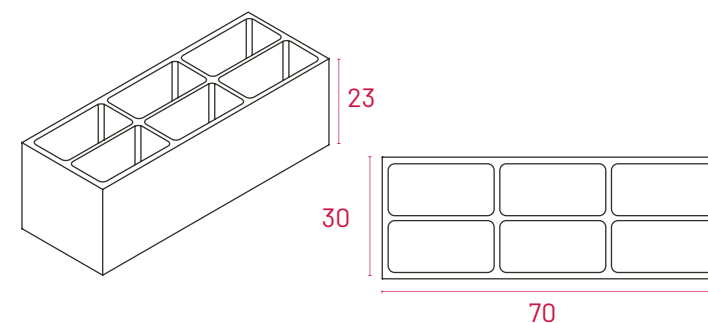

Colores disponibles



Gris

Propiedades del producto



Fuego



Sostenible







Arquetas

GlobalEPD

A VERIFIED ENVIRONMENTAL DECLARATION

Arquetas

ARQUETAS

Con fondo	172
Sin fondo	173
Tapas	174

Prefabricados Duero, fabrica arquetas de hormigón con fondo y sin fondo de la mayor calidad del mercado. Son arquetas estándar desde 30×30 cm hasta 100×100 cm siendo ideales y necesarias para realizar las conexiones entre distintas instalaciones, para conexiones eléctricas y redes de distribución de servicios de cableados de telecomunicaciones, redes de saneamiento...

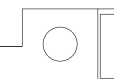

Arquetas **CON FONDO**

Especificaciones técnicas.

Fabricados conforme a la norma **UNE 133100-2**.

ANCHURA ÚTIL a (mm)	ANCHURA TOTAL A (mm)	ALTURA ÚTIL h (mm)	ALTURA TOTAL H (mm)	ESPESOR PARED e (mm)	PESO POR UNIDAD P (kg)	DIÁMETRO EMBOCADURAS D (mm)	NÚMERO EMBOCADURAS N (ud)
300	370	290	330	35	43	130	3
400	480	390	430	40	86	220	3
500	600	490	540	50	160	320	3
600	720	580	640	60	260	420	3
700	840	690	760	70	410	500	3
800	960	790	870	80	580	550	3
1.000	1.220	950	1.060	110	1.250	740	3

*Los pesos y medidas son valores orientativos.

Medidas

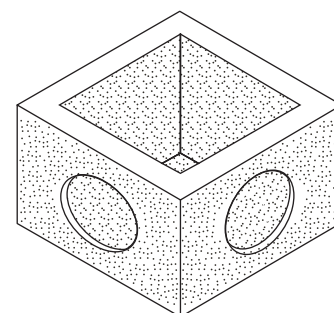
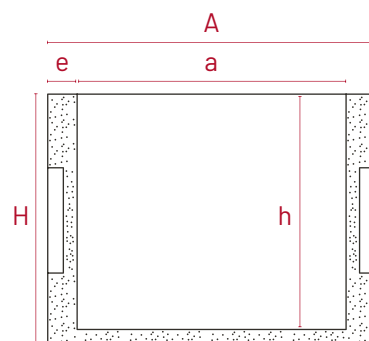

Propiedades del producto



Sostenible

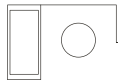

Arquetas SIN FONDO

Especificaciones técnicas.

Fabricados conforme a la norma **UNE 133100-2**.

ANCHURA ÚTIL a (mm)	ANCHURA TOTAL A (mm)	ALTURA ÚTIL h (mm)	ALTURA TOTAL H (mm)	ESPESOR PARED e (mm)	PESO POR UNIDAD P (kg)	DIÁMETRO EMBOCADURAS D (mm)	NÚMERO EMBOCADURAS N (ud)
300	370	330	330	35	37	130	3
400	480	430	430	40	75	220	3
500	600	540	540	50	136	320	3
600	720	640	640	60	214	420	3
700	840	760	760	70	340	500	3
800	960	870	870	80	550	550	3
1.000	1.220	1.060	1.060	110	1.050	740	3

*Los pesos y medidas son valores orientativos.

Medidas

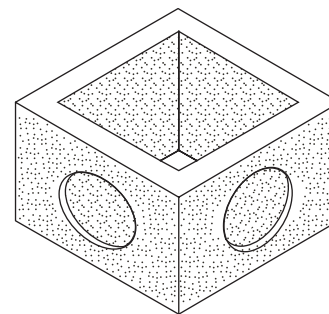
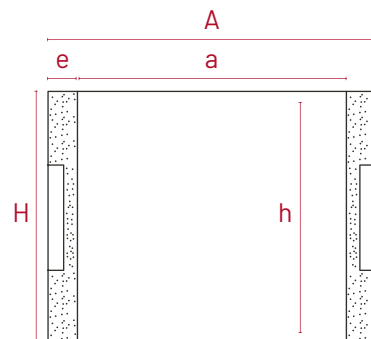

Propiedades del producto



Sostenible

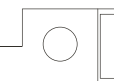

Tapa DE ARQUETA

Especificaciones técnicas.

Fabricados conforme a la norma **UNE 133100-2**.

LONGITUD TOTAL A (mm)	ESPELOR h (mm)	TAPA REGISTRO	PESO POR UNIDAD P (kg)
400	60	28x28	21
490	60	37x37	33
600	80	43x43	65
700	80	56x56	90
800	80	56x56	125
950	80	56x56	160
1.220	115	67x67	390

*Los pesos y medidas son valores orientativos.

Medidas

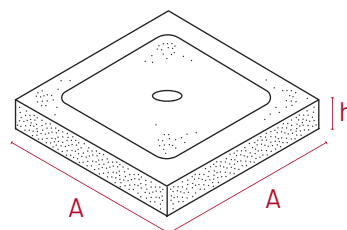
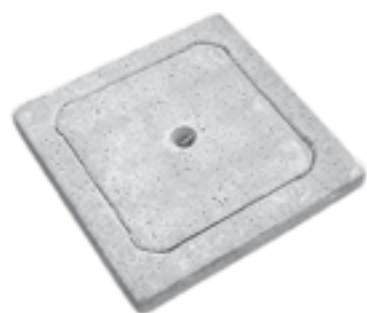

Propiedades del producto



Sostenible

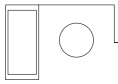



Tubos

GlobalEPD

A VERIFIED ENVIRONMENTAL DECLARATION

Tubos

MASA

Machiembrado	179
Campana	180
Aros de pozo	181
Cono simétrico	182
Cono asimétrico	183

ARMADOS

Aros de pozo	185
Cono simétrico	186
Cono asimétrico	187
Machiembrado	188
Campana	189



Tubos

MASA

Los tubos de hormigón en masa de Prefabricados Duero son una solución sostenible y ecológica para la canalización de aguas y residuos. Son la mejor opción ya que son altamente resistentes a la abrasión y la corrosión, lo que les permite tener una vida útil superior a otros materiales.

Tubos de hormigón MASA

Machihembrado

Especificaciones técnicas.

Fabricados conforme a la norma **UNE 127916**.

DIÁMETRO NOMINAL Dn (mm)	DIÁMETRO EXTERIOR D (mm)	LOGITUD ÚTIL Lu (mm)	LOGITUD TOTAL L (mm)	ESPESOR PARED e (mm)	PESO POR UNIDAD P (kg)
300	380	1.000	1.020	40	98
400	490	1.000	1.020	45	133
500	600	1.000	1.020	50	201
600	720	1.000	1.020	60	287
800	950	1.000	1.020	75	540
1.000	1.160	1.000	1.020	80	661
1.200	1.400	1.000	1.020	100	1.120

*Los pesos y medidas son valores orientativos.

Medidas

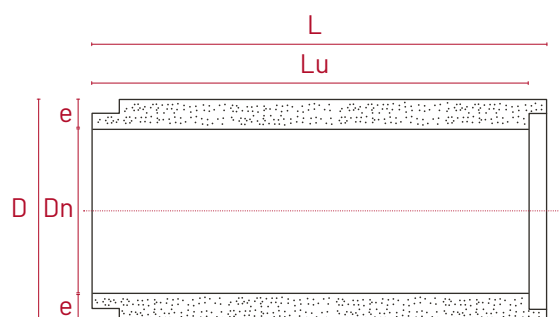

Propiedades del producto



Sostenible

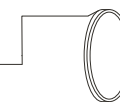

Tubos de hormigón **MASA**

Campana

Especificaciones técnicas.

Fabricados conforme a la norma **UNE 127916**.

DIÁMETRO NOMINAL Dn (mm)	DIÁMETRO EXTERIOR D (mm)	DIÁMETRO EXTERIOR CAMPANA D (mm)	LOGITUD ÚTIL Lu (mm)	LOGITUD TOTAL L (mm)	ESPESOR PARED e (mm)	PESO POR UNIDAD P (kg)
300	390	480	2.000	2.100	45	271
400	510	600	2.000	2.100	55	440
500	620	730	2.000	2.100	70	740
600	730	850	2.000	2.100	80	930

*Los pesos y medidas son valores orientativos.

Medidas

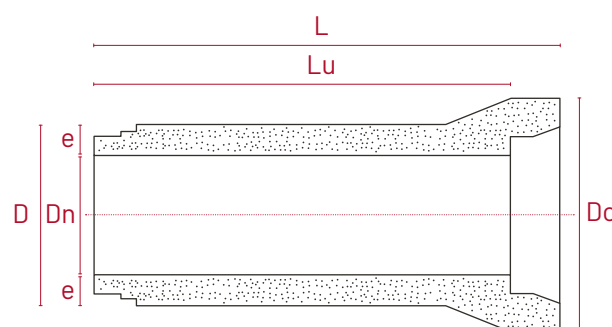

Propiedades del producto



Sostenible

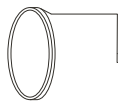

Tubos de hormigón **MASA**

Aros de Pozo

Especificaciones técnicas.

Fabricados conforme a la norma **UNE 127916**.

DENOMINACIÓN	DIÁMETRO ÚTIL D (mm)	LOGITUD ÚTIL Lu (mm)	LOGITUD TOTAL L (mm)	ESPESOR PARED e (mm)	PESO POR UNIDAD P (kg)
1.000x500	1.000	500	530	80	330
1.000x1.000	1.000	1.000	1.040	80	660

*Los pesos y medidas son valores orientativos.

*Los pesos y medidas son valores orientativos.



Medidas

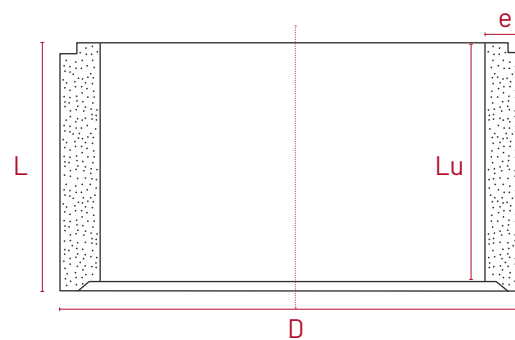

Propiedades del producto



Sostenible

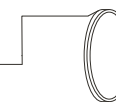

Tubos de hormigón MASA

Cono Simétrico

Especificaciones técnicas.

Fabricados conforme a la norma **UNE 127916**.

DENOMINACIÓN	DIÁMETRO MÁXIMO D (mm)	DIÁMETRO MÍNIMO D (mm)	LOGITUD TOTAL L (mm)	ESPEJOR PARED e (mm)	PESO POR UNIDAD P (kg)
1.000	1.000	600	660	75	316

*Los pesos y medidas son valores orientativos.

Medidas

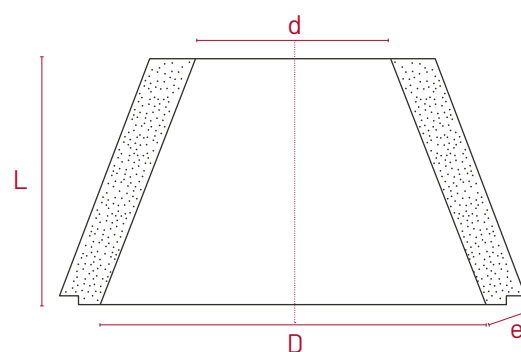

Propiedades del producto



Sostenible

Tubos de hormigón **MASA**

Cono Asimétrico

Especificaciones técnicas.

Fabricados conforme a la norma **UNE 127916**.

DENOMINACIÓN	DIÁMETRO MÁXIMO D (mm)	DIÁMETRO MÍNIMO D (mm)	LOGITUD TOTAL L (mm)	ESPESOR PARED e (mm)	PESO POR UNIDAD P (kg)
800	800	600	630	75	292
1.000	1.000	600	770	80	471

*Los pesos y medidas son valores orientativos.



Medidas

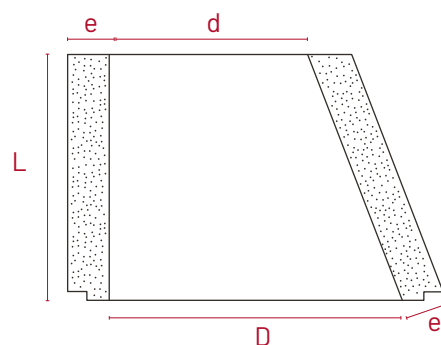

Propiedades del producto



Sostenible



Tubos

TUBOS ARMADOS

Los tubos de hormigón armado son la opción más resistente y sostenible para la instalación de redes de saneamiento, drenaje y otras canalizaciones hidráulicas. La resistencia mecánica de estos tubos se debe a la incorporación de una armadura de acero en su estructura, que les proporciona una gran capacidad de carga y resistencia a la deformación.

Tubos de hormigón **ARMADO**

Aros de Pozo

Especificaciones técnicas.

Fabricados conforme a la norma **UNE 127916**.

DENOMINACIÓN	DIÁMETRO ÚTIL D (mm)	LOGITUD ÚTIL Lu (mm)	LOGITUD TOTAL L (mm)	ESPESOR PARED e (mm)	PESO POR UNIDAD P (kg)
1.000x500	1.000	500	530	80	330
1.000x1.000	1.000	1.000	1.040	80	660

*Los pesos y medidas son valores orientativos.

*Los pesos y medidas son valores orientativos.



Medidas

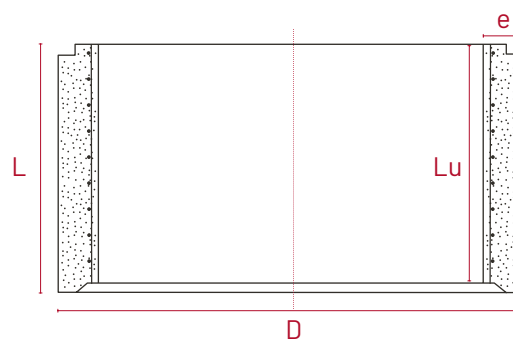

Propiedades del producto



Sostenible

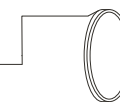

Tubos de hormigón **ARMADO**

Cono Simétrico

Especificaciones técnicas.

Fabricados conforme a la norma **UNE 127916**.

DENOMINACIÓN	DIÁMETRO MÁXIMO D (mm)	DIÁMETRO MÍNIMO D (mm)	LOGITUD TOTAL L (mm)	ESPELOR PARED e (mm)	PESO POR UNIDAD P (kg)
1.000	1.000	600	660	75	316

*Los pesos y medidas son valores orientativos.



Medidas

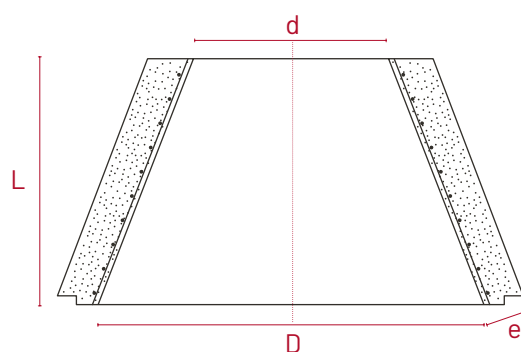

Propiedades del producto



Sostenible

Tubos de hormigón ARMADO

Cono Asimétrico

Especificaciones técnicas.

Fabricados conforme a la norma **UNE 127916**.

DENOMINACIÓN	DIÁMETRO MÁXIMO D (mm)	DIÁMETRO MÍNIMO D (mm)	LOGITUD TOTAL L (mm)	ESPESOR PARED e (mm)	PESO POR UNIDAD P (kg)
800	800	600	630	75	292
1.000	1.000	600	770	80	471

*Los pesos y medidas son valores orientativos.



Medidas

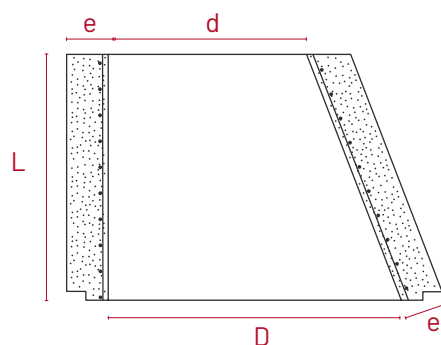

Propiedades del producto



Sostenible

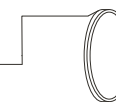

Tubos de hormigón **ARMADO**

Machihembrado

Especificaciones técnicas.

Fabricados conforme a la norma **UNE 127916**.

DIÁMETRO NOMINAL Dn (mm)	DIÁMETRO EXTERIOR D (mm)	LOGITUD ÚTIL Lu (mm)	LOGITUD TOTAL L (mm)	ESPELOR PARED e (mm)	PESO POR UNIDAD P (kg)
1.500	1.820	2.300	2.400	160	4.800
1.800	2.160	2.300	2.400	180	6.335
2.000	2.420	2.300	2.400	210	8.340

*Los pesos y medidas son valores orientativos.



Medidas

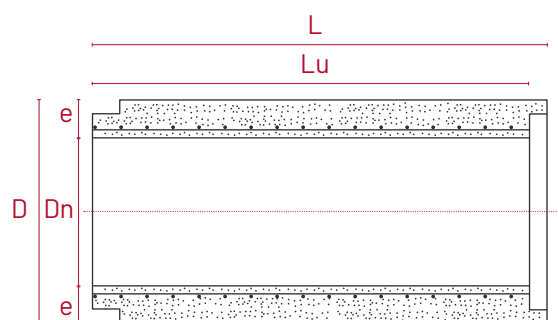

Propiedades del producto



Sostenible

Tubos de hormigón **ARMADO**

Campana

Especificaciones técnicas.

Fabricados conforme a la norma **UNE 127916**.

DIÁMETRO NOMINAL Dn (mm)	DIÁMETRO EXTERIOR D (mm)	DIÁMETRO EXTERIOR CAMPANA D (mm)	LOGITUD ÚTIL Lu (mm)	LOGITUD TOTAL L (mm)	ESPESOR PARED e (mm)	PESO POR UNIDAD P (kg)
300	390	480	2.000	2.100	45	271
400	510	600	2.000	2.100	55	440
500	620	730	2.000	2.100	70	740
600	730	850	2.000	2.100	80	930
700	870	1.055	2.000	2.100	85	1.240
800	990	1.170	2.000	2.100	95	1.440
1.000	1.220	1.435	2.000	2.100	110	2.160
1.200	1.450	1.700	2.000	2.100	125	2.910

*Los pesos y medidas son valores orientativos.

Medidas

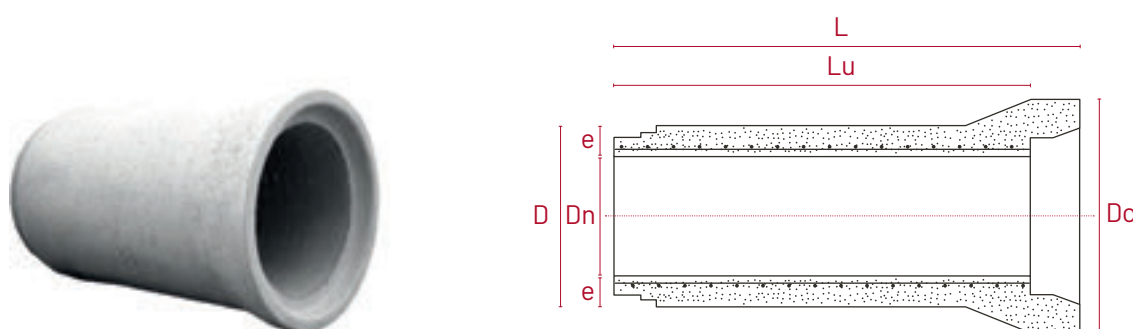

Propiedades del producto



Sostenible



Marcos de hormigón

GlobalEPD

A VERIFIED ENVIRONMENTAL DECLARATION

Marcos de hormigón

MARCOS

Los marcos de hormigón prefabricados son una solución rentable y eficiente para la construcción de estructuras de hormigón, ya que se fabrican en condiciones controladas de fábrica y se transportan a la obra ya terminados, lo que permite ahorrar tiempo y costes en la construcción. Además, al ser prefabricados, se minimiza la necesidad de mano de obra en la obra civil, lo que reduce los riesgos laborales y aumenta la seguridad en la construcción.



Pasos inferiores de calidad

Fabricamos marcos prefabricados de hormigón armado, de diferentes medidas, tanto de junta machihembrada como con junta plana. Fabricamos marcos de una sola pieza (cuadrada o rectangular), o de dos piezas, articulados, solamente para los de grandes dimensiones. Se usa en obra civil, para todo tipo de obras, tanto de carreteras como de ferrocarriles







Forjados y ferrallas

Global **EPD**

A VERIFIED ENVIRONMENTAL DECLARATION

Forjados y ferrallas

FORJADOS Y FERRALLAS

En Prefabricados Duero somos expertos en la fabricación de forjados y ferrallas de alta calidad. Contamos con un equipo humano altamente capacitado y con amplia experiencia en el sector, así como con unas modernas instalaciones y la tecnología más avanzada para el cálculo, diseño y elaboración de ferralla que ponemos a disposición de nuestros clientes.

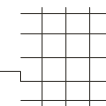

Cualquier estructura, la hacemos

Disponemos de un equipo humano con contrastada experiencia, de unas modernas instalaciones y de la más avanzada tecnología para el cálculo, diseño y elaboración de ferralla que ponemos a disposición de nuestros clientes. Todas las materias primas empleadas en la fabricación de armaduras y forjados responden a las exigencias de fabricación y cumplimiento de sus características químicas, mecánicas, de adherencia y soldabilidad conforme con la normativa en vigor. Las viguetas armadas y prelosas armadas cuentan ambas con marcado CE, respondiendo a las normas **UNE-EN 15037-10** y **UNE-EN 13747-11** respectivamente. Fabricamos todo tipo de forjados, tanto unidireccionales, con viguetas armadas y pretensadas, como placas armadas y reticulares, fabricando tanto las bovedillas como los casetones.



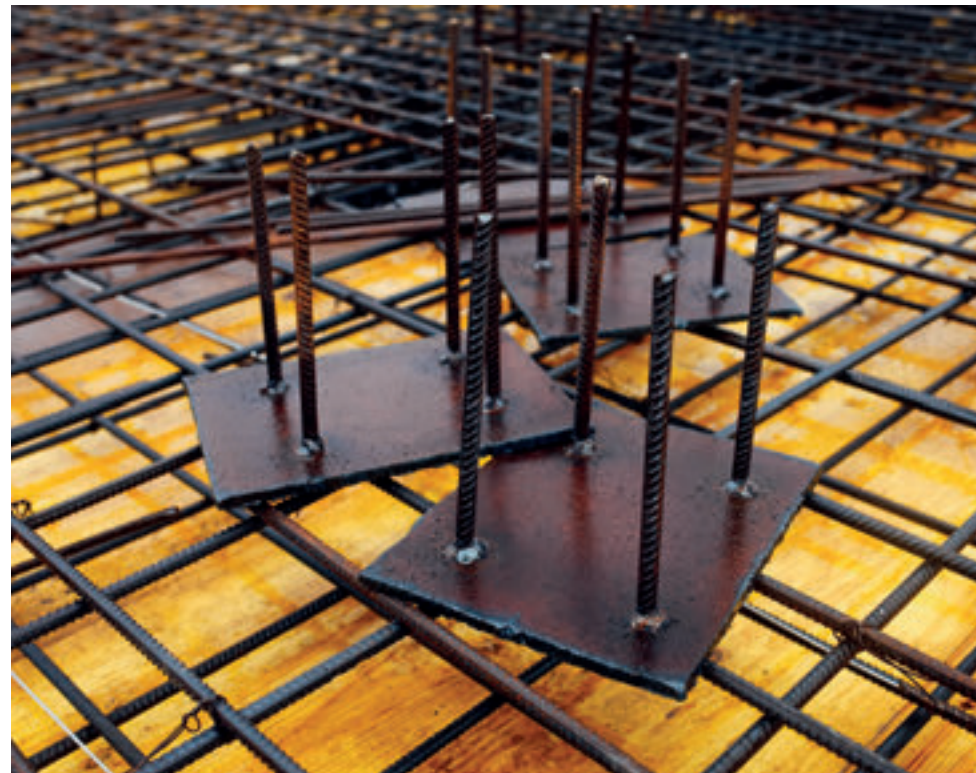
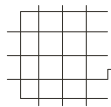



Áridos ensacados

Global **EPD**

A VERIFIED ENVIRONMENTAL DECLARATION

Áridos ensacados

ÁRIDOS ENSACADOS

Llevamos el árido hasta cualquier lugar, sea el tamaño de la obra que sea, con sacos de 20 o 25 kg y en big bag de 1000 kg. Nuestros sacos de árido cuentan con su correspondiente marcado CE, lo que garantiza su calidad y seguridad.



LLevando el árido hasta cualquier lugar

GlobalEPD
A VERIFIED ENVIRONMENTAL DECLARATION

Fabricamos sacos de áridos de 20 o 25 kg. Ensacamos cualquier árido, con su correspondiente marcado CE, para poder llegar hasta cualquier obra, sea el tamaño que sea. También vendemos el árido en big bag de 1000 kg.







Áridos

Global **EPD**

A VERIFIED ENVIRONMENTAL DECLARATION

ÁRIDOS

Nuestros áridos silíceos son ampliamente utilizados en la construcción, tanto para la fabricación de hormigón como para mezclas bituminosas y morteros. Los diferentes tamaños y grados de los áridos que ofrecemos permiten a los clientes adaptarse a cualquier necesidad específica de su proyecto de construcción.



LLevando el árido hasta cualquier lugar

GlobalEPD
A VERIFIED ENVIRONMENTAL DECLARATION

Extraemos áridos silíceos de nuestras propios terrenos situados en la cuenca del Duero, en las inmediaciones del municipio de Toro. Los áridos son extraídos con maquinaria de la más alta tecnología y transportados hasta las plantas para su tratamiento y selección. Ponemos a disposición de los clientes una gran variedad de áridos, tanto naturales como machacados. Los naturales sufren un proceso de lavado y cribado que los clasifica en sus diferentes tamaños y para el machacado, se parte del árido natural que es triturado en diferentes dimensiones y cribado posteriormente, el resultado final se acopia o se ensaca y se pone a la venta. Disponemos de todos los certificados CE necesarios para su distribución y venta, tanto para áridos, para hormigón, para mezclas bituminosas y para morteros. Este marcado CE conlleva un férreo control que realizamos en nuestro propio laboratorio de control de calidad.







Hormigones

Global **EPD**

A VERIFIED ENVIRONMENTAL DECLARATION

Hormigones

HORMIGONES

Contamos con cinco plantas de producción ubicadas estratégicamente en Toro I, Toro II, Tordesillas, Villardefrades y Coreses, por lo que estamos convenientemente ubicados para atender las necesidades de nuestros clientes en toda la región.



Con el h3rmigon se puede hacer casi de todo

Contamos con cinco plantas: Toro I, Toro II, Tordesillas, Villardefrades y Coreses. Disponemos de una amplia gama de hormigones por resistencia y por dosificaci3n. Todas las plantas est3n certificadas por AENOR para la producci3n y distribuci3n de hormig3n preamasado de resistencia caracter3stica hasta 50 N/mm². Las materias primas constituyentes disponen de marcado CE para asegurar as3 la mejor calidad de nuestros hormigones y morteros, adem3s se le realizan controles peri3dicos al producto final seg3n marca la normativa vigente. Las plantas de las que disponemos son:





Toro I

Ctra. Toro-Salamanca
Km 2,5
Toro (Zamora)
Tfno: 615 56 27 93



Toro II

Ctra. Medina de Rioseco
Km 1
Toro (Zamora)
Tfno: 615 56 27 93



Villardefrades

Ctra. Medina de Rioseco - Toro, Km 24.7
Villardefrades (Valladolid)
Tfno: 617 379 706



Tordesillas

N-122, Km 398
Tordesillas (Valladolid)
Tfno: 669 31 13 62



Coreses

Coreses
Ctra. Tordesillas, Km 9
Sitio Las Cañadas s/n
Coreses (Zamora)
Tfno: 617 37 97 00



Transportes y maquinaria

Global **EPD**

A VERIFIED ENVIRONMENTAL DECLARATION

Transportes y maquinaria

TRANSPORTES Y MAQUINARIA

Desde JIT (José Isidro Torres) ponemos a tu disposición una amplia variedad de servicios de transporte y maquinaria para cubrir todas las necesidades de tu proyecto. Nos esforzamos por cumplir con tus expectativas al proporcionar servicios rápidos y eficientes para cualquier tipo de proyecto, ya sea pequeño o grande.



Llegamos a todos los sitios

Disponemos de una moderna flota de más de cien vehículos y de un personal altamente cualificado para la ejecución de excavaciones y para el transporte de mercancías. La maquinaria para el movimiento de tierras se alquila con conductor y consta de palas cargadoras, retroexcavadoras de cadenas, retroexcavadoras de ruedas y retroexcavadoras mixtas. En el campo del transporte ofrecemos servicios para el transporte de árido, cemento, maquinaria, hormigón, transportes especiales y cualquier mercancía que se nos solicite. Para ello contamos con: Hormigoneras, Bombas de hormigón, Cabezas tractoras, Dumpers, Bañeras, Góndolas, Plataformas, Cisternas de cemento, Camiones pluma.







XPdE



SECCO



Gama EcoLife[®]

Pavimentos para ser vividos naturalmente



eCC life

La gama ECOlife® es el fruto de la apuesta por la innovación de PREFABRICADOS Duero para crear un futuro más sostenible y habitable en nuestras ciudades, que da respuesta a los tres grandes retos medioambientales de nuestros núcleos urbanos:

- Gestionar el agua de lluvia
- Reducir la emisión de gases contaminantes
- Mitigar el efecto "Isla de Calor"



ECOlife[®], pavimentos para ser vividos naturalmente

Innovamos para mitigar el impacto medioambiental en las ciudades aplicando soluciones tecnológicas a nuestros pavimentos capaces de reducir la contaminación del aire y recuperar el agua para nuestros suelos.



Tratamiento fotocatalítico

La gama de pavimentos capaz de descontaminar el aire que respiramos mediante fotocatalisis

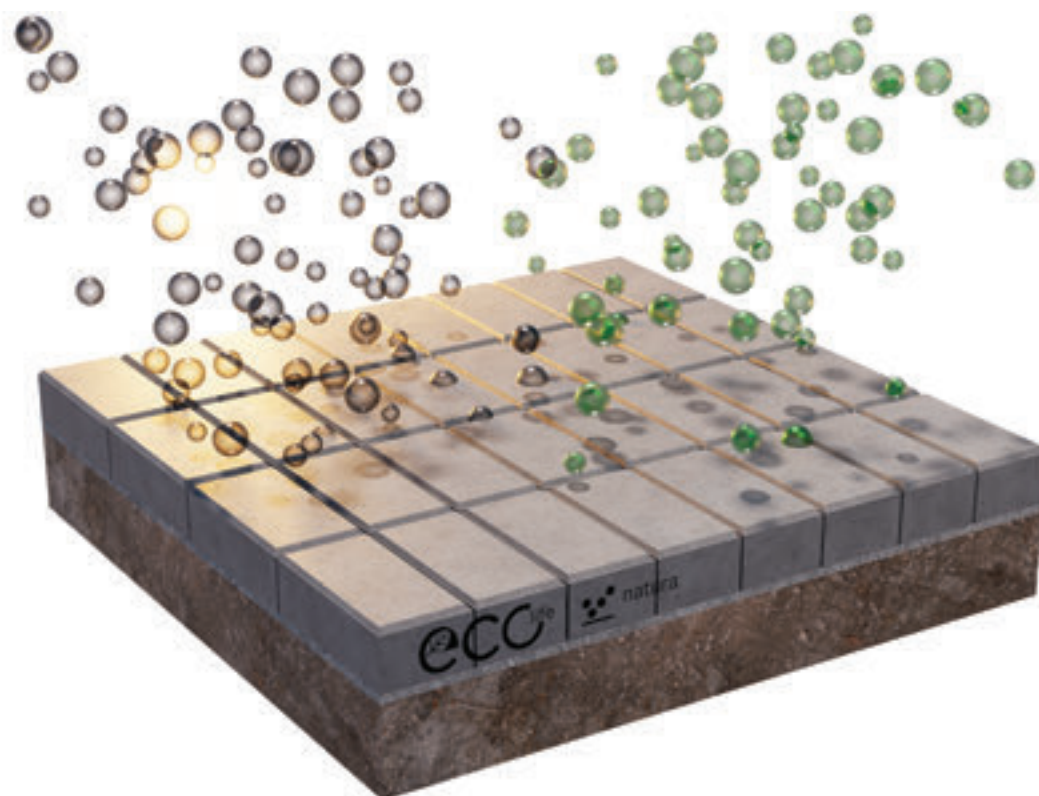

ECOlife[®], pavimentos para ser vividos naturalmente

Innovamos para mitigar el impacto medioambiental en las ciudades aplicando soluciones tecnológicas a nuestros pavimentos capaces de reducir la contaminación del aire y recuperar el agua para nuestros suelos.



Sistema Urbano de Drenaje Sostenible

La gama de pavimentos de hormigón permeables capaz de devolver el agua a su ciclo natural

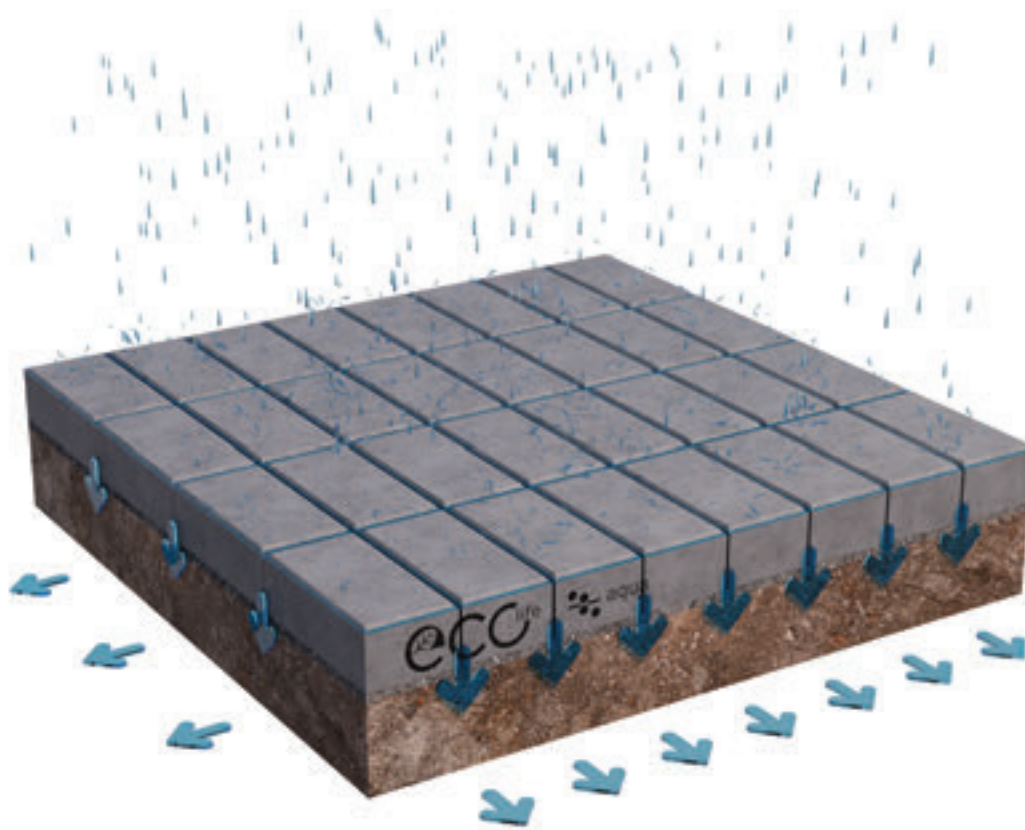



Natura

Global EPD

A VERIFIED ENVIRONMENTAL DECLARATION



Un aire más limpio para nuestras ciudades

La gama de pavimentos capaz de descontaminar el aire que respiramos mediante fotocatálisis



ECOLife® natura

ADOQUINES

Los adoquines de hormigón de Prefabricados Duero destacan por su resistencia a la abrasión y al desgaste, así como por su gran estabilidad, lo que los hace ideales para su uso en espacios exteriores con alto tráfico, como calles, plazas, parques y áreas públicas en general.

Adoquines | natura

10x10 MORALES

Especificaciones técnicas.

Fabricados conforme a la norma **UNE-EN 1338**.

ESPESOR (h)	KG/M ²	M ² /PALET	KG/PALET	ARISTAS
6	140	5	700	45°
8	180	5	900	45°

*Los pesos y medidas son valores orientativos.



Medidas

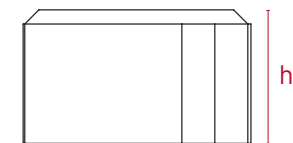
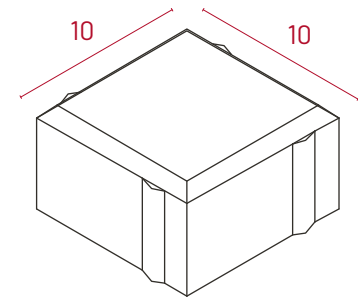

Colores disponibles

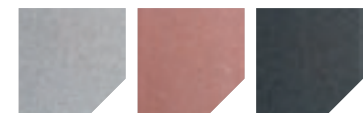

Gris

Rojo

Negro



Crema Tostado Blanco

Propiedades del producto



Hidrofugado



Bicapa



Sostenible



Ecológico



Adoquines



12x12 ALCAÑICES

Especificaciones técnicas.

Fabricados conforme a la norma **UNE-EN 1338**.

ESPESOR (h)	KG/M ²	M ² /PALET	KG/PALET	ARISTAS
6	140	6,45	930	45° / redonda

*Los pesos y medidas son valores orientativos.



Medidas

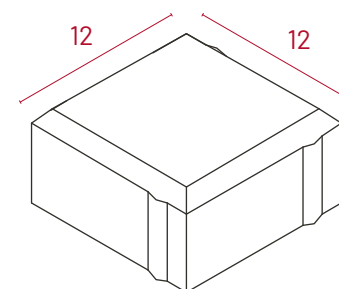

Colores disponibles



Gris Rojo Negro



Crema Tostado Blanco

Propiedades del producto



Hidrofugado



Bicapa



Sostenible



Ecológico

Adoquines | natura

20x10 TORO

Especificaciones técnicas.

Fabricados conforme a la norma **UNE-EN 1338**.

ESPESOR (h)	KG/M ²	M ² /PALET	KG/PALET	ARISTAS
6	140	10	1.400	45° / 90°
8	180	10	1.800	45° / 90°
10	220	7	1.585	45° / 90°

*Los pesos y medidas son valores orientativos.



Medidas

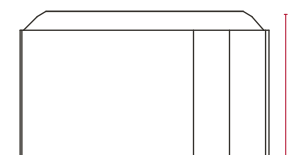
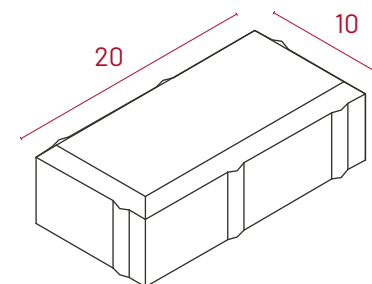

Colores disponibles



Gris Rojo Negro



Crema Tostado Blanco

Propiedades del producto



Hidrofugado



Bicapa



Sostenible



Ecológico

Disponible en:





Adoquines | natura

24x12 **GUAREÑA**

Especificaciones técnicas.

Fabricados conforme a la norma **UNE-EN 1338**.

ESPESOR (h)	KG/M ²	M ² /PALET	KG/PALET	ARISTAS
6	140	9,22	1.330	45°/ redonda

*Los pesos y medidas son valores orientativos.



Disponible en:



Medidas

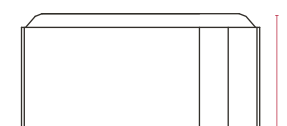
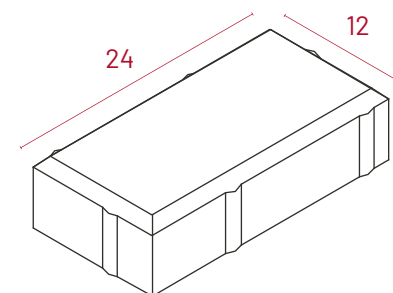

Colores disponibles



Gris Rojo Negro



Crema Tostado Blanco

Propiedades del producto



Hidrofugado



Bicapa



Sostenible



Ecológico





Adoquines



23x12 CORESES

Especificaciones técnicas.

Fabricados conforme a la norma **UNE-EN 1338**.

ESPESOR (h)	KG/M ²	M ² /PALET	KG/PALET	ARISTAS
6	140	9	1.260	45°
8	180	9	1.640	45°

*Los pesos y medidas son valores orientativos.



Medidas

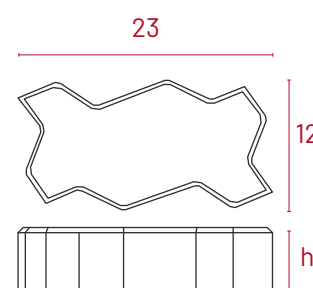
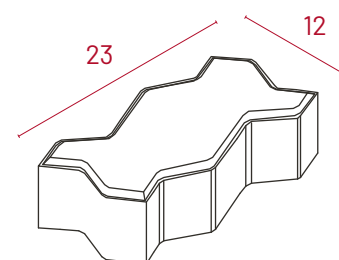

Colores disponibles



Gris Rojo Negro



Crema Tostado Blanco

Propiedades del producto



Hidrofugado



Bicapa



Sostenible



Ecológico

Adoquines | natura

18-12-9x12 CASTELLANO

Especificaciones técnicas.

Fabricados conforme a la norma **UNE-EN 1338**.

ESPESOR (h)	KG/M ²	M ² /PALET	KG/PALET	ARISTAS
6	140	10	1.400	45°
8	180	10	1.800	45°/ 90°

*Los pesos y medidas son valores orientativos.



Disponible en:



Medidas

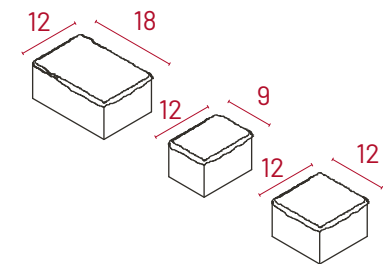

Colores disponibles



Propiedades del producto





Adoquines



20x16 BENAVENTE

Especificaciones técnicas.

Fabricados conforme a la norma **UNE-EN 1338**.

ESPESOR (h)	KG/M ²	M ² /PALET	KG/PALET	ARISTAS
8	180	8,6	1.548	45°

*Los pesos y medidas son valores orientativos.



Medidas

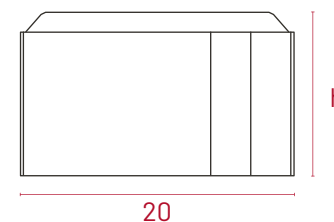
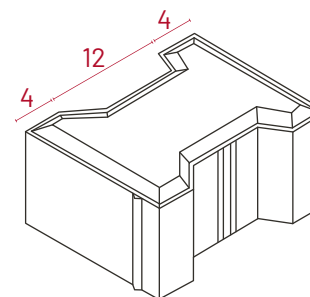

Colores disponibles



Gris Rojo Negro



Crema Tostado Blanco

Propiedades del producto



Hidrofugado



Bicapa



Sostenible



Ecológico





ECOLife® natura

BALDOSAS

Los beneficios del uso de baldosas de hormigón de Prefabricados Duero incluyen su alta resistencia, durabilidad y facilidad de mantenimiento. Además, estas baldosas son resistentes al deslizamiento y ofrecen una excelente tracción en superficies mojadas, lo que las hace ideales para áreas al aire libre, como patios, piscinas, terrazas y caminos de jardín.

Baldosas | natura

20x20 ALISTE

Especificaciones técnicas.

Fabricados conforme a la norma **UNE-EN 1339**.

ESPESOR (h)	KG/M ²	M ² /PALET	KG/PALET	ARISTAS
6	140	10	1.400	45°
8	180	10	1.850	45°/ 90°

*Los pesos y medidas son valores orientativos.

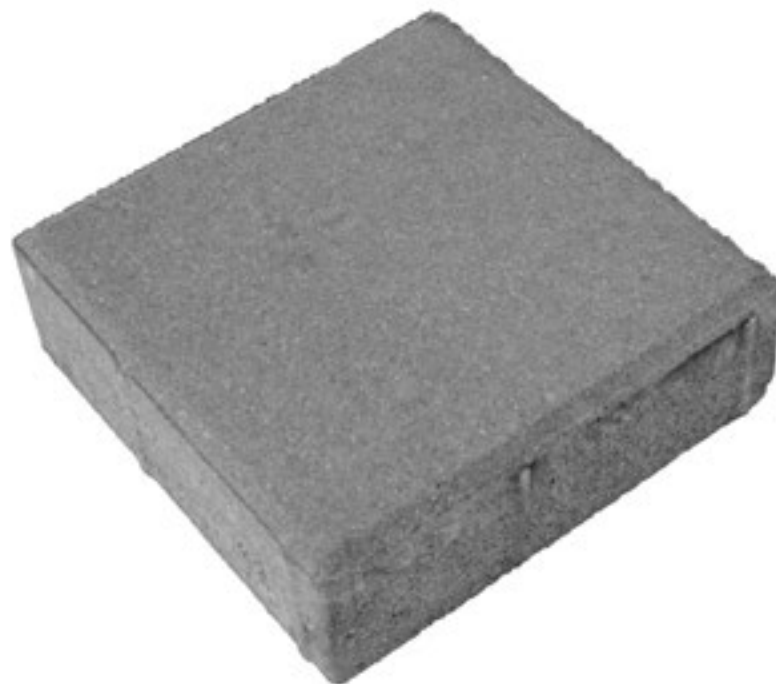

Medidas

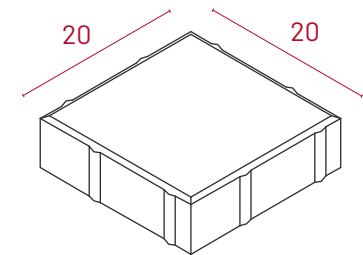

Colores disponibles

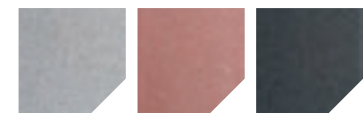

Gris Rojo Negro



Crema Tostado Blanco

Propiedades del producto



Hidrofugado



Bicapa



Sostenible



Ecológico

Disponible en:





Baldosas



30x30 TÁBARA

Especificaciones técnicas.

Fabricados conforme a la norma **UNE-EN 1339**.

ESPESOR (h)	KG/M ²	M ² /PALET	KG/PALET	ARISTAS
6	140	8,1	1.134	45°

*Los pesos y medidas son valores orientativos.



Medidas

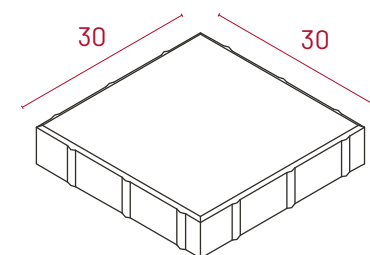

Colores disponibles



Gris Rojo Negro



Crema Tostado Blanco

Propiedades del producto



Hidrofugado



Bicapa



Sostenible



Ecológico

Baldosas



40x20 COLEGIATA

Especificaciones técnicas.

Fabricados conforme a la norma **UNE-EN 1339**.

ESPESOR (h)	KG/M ²	M ² /PALET	KG/PALET	ARISTAS
6	140	9,6	1.400	45°/90°
8	180	9,6	1.750	90°

*Los pesos y medidas son valores orientativos.

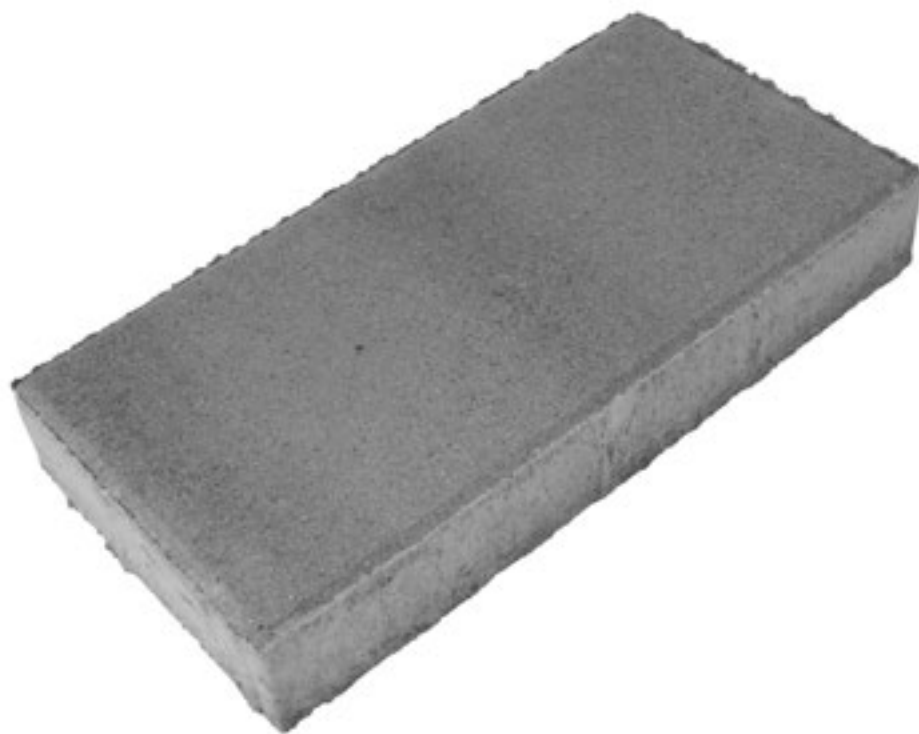

Disponible en:



Medidas

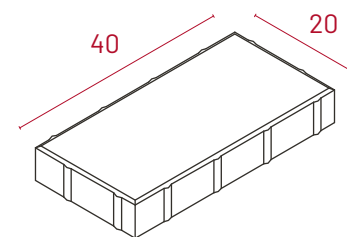

Colores disponibles



Gris Rojo Negro



Crema Tostado Blanco

Propiedades del producto



Hidrofugado



Bicapa



Sostenible



Ecológico



Baldosas



40x40

SAYAGO

Especificaciones técnicas.

Fabricados conforme a la norma **UNE-EN 1339**.

ESPESOR (h)	KG/M ²	M ² /PALET	KG/PALET	ARISTAS
6	140	9,6	1.370	90°

*Los pesos y medidas son valores orientativos.



Medidas

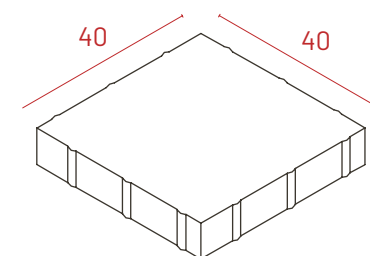

Colores disponibles



Gris Rojo Negro



Crema Tostado Blanco

Propiedades del producto



Hidrofugado



Bicapa



Sostenible



Ecológico

Disponible en:



Baldosas



50x50 TERA

Especificaciones técnicas.

Fabricados conforme a la norma **UNE-EN 1339**.

ESPESOR (h)	KG/M ²	M ² /PALET	KG/PALET	ARISTAS
6	140	10	1.420	90°
8	180	10	1.850	90°

*Los pesos y medidas son valores orientativos.



Disponible en:



Medidas

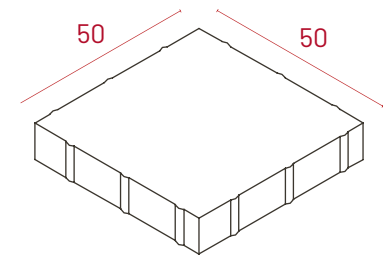

Colores disponibles

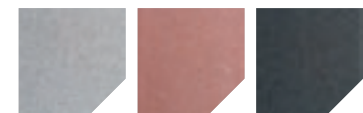

Gris Rojo Negro



Crema Tostado Blanco

Propiedades del producto



Hidrofugado



Bicapa



Sostenible



Ecológico



Baldosas | natura

60x40 **SANABRIA**

Especificaciones técnicas.

Fabricados conforme a la norma **UNE-EN 1339**.

ESPESOR (h)	KG/M ²	M ² /PALET	KG/PALET	ARISTAS
6	140	11,52	1.630	90°
8	180	10,08	1.850	90°

*Los pesos y medidas son valores orientativos.

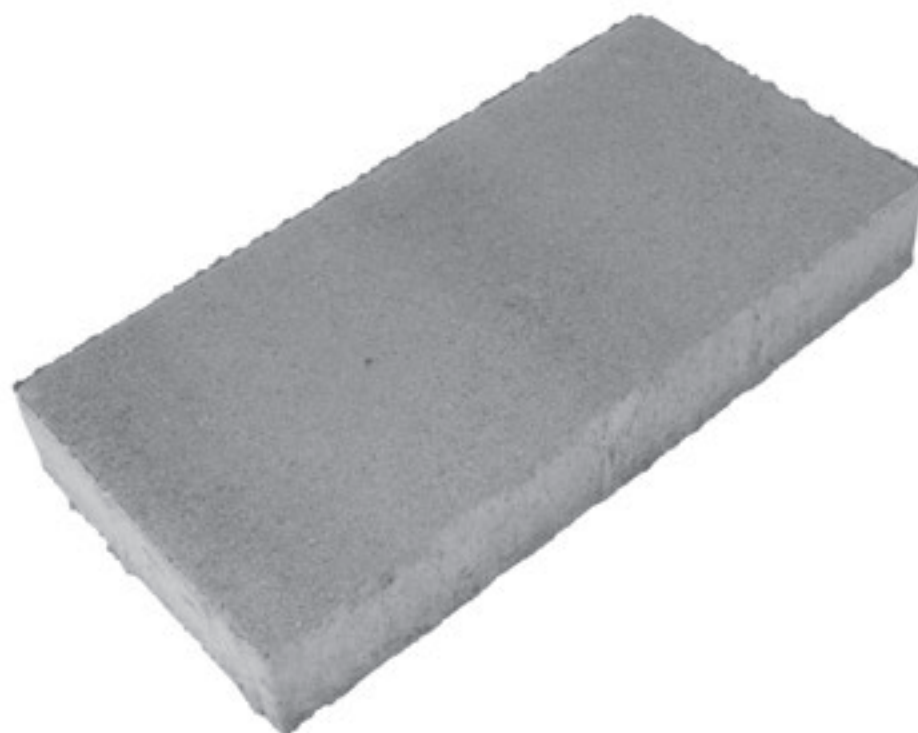

Medidas

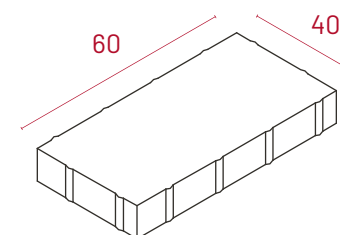

Colores disponibles



Propiedades del producto



Disponible en:







Aqua

GlobalEPD

A VERIFIED ENVIRONMENTAL DECLARATION



Sistema Urbano de Drenaje Sostenible

La gama de pavimentos de hormigón permeables capaz de devolver el agua a su ciclo natural

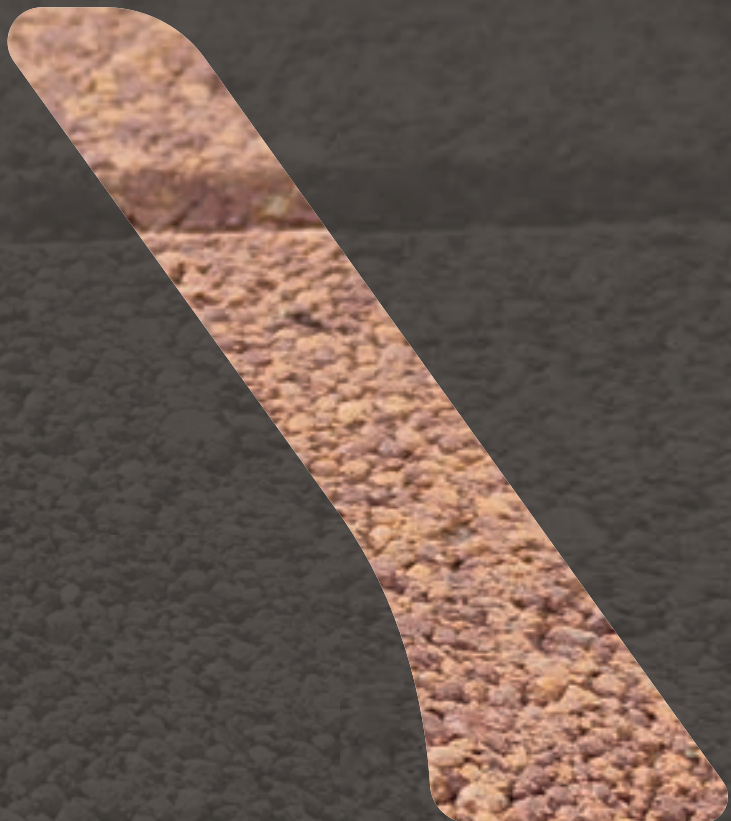
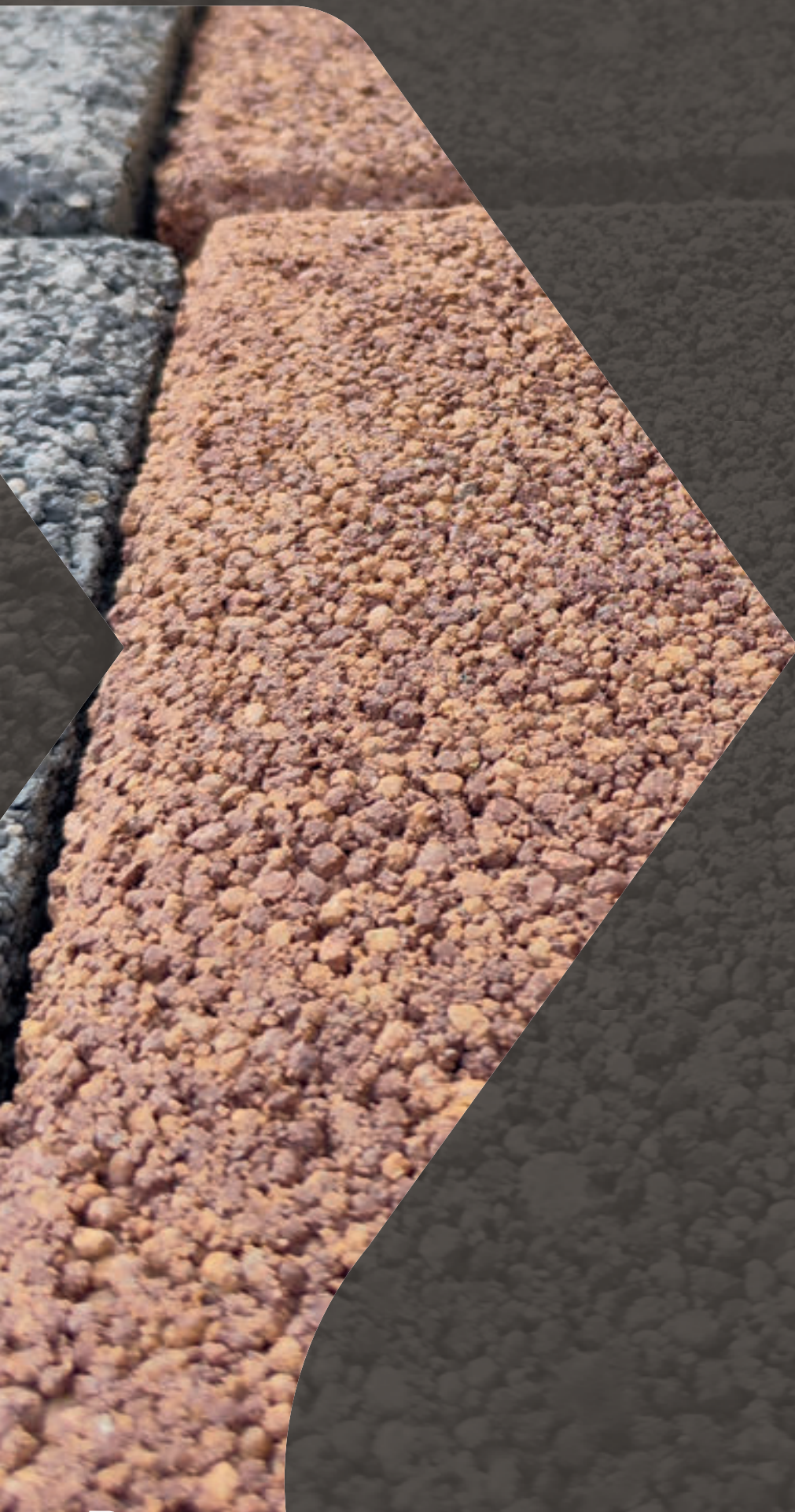

ECOLife® aqua

ADOQUINES

Los adoquines de hormigón de Prefabricados Duero destacan por su resistencia a la abrasión y al desgaste, así como por su gran estabilidad, lo que los hace ideales para su uso en espacios exteriores con alto tráfico, como calles, plazas, parques y áreas públicas en general.

Adoquines



20x10 TORO

Especificaciones técnicas.

Fabricados conforme a la norma **UNE-EN 1338**.

ESPESOR (h)	KG/M ²	M ² /PALET	KG/PALET	ARISTAS
6	140	10	1.400	45° / 90°
8	180	10	1.800	45° / 90°
10	220	7	1.585	45° / 90°

*Los pesos y medidas son valores orientativos.



Medidas

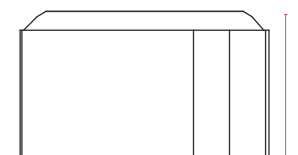
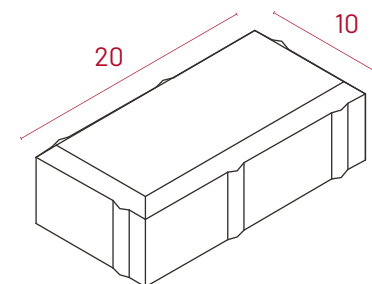

Colores disponibles



Gris Rojo Negro



Crema Tostado Blanco

Propiedades del producto



Hidrofugado



Bicapa



Sostenible



Ecológico

Disponible en:





Adoquines



24x12 **GUAREÑA**

Especificaciones técnicas.

Fabricados conforme a la norma **UNE-EN 1338**.

ESPESOR (h)	KG/M ²	M ² /PALET	KG/PALET	ARISTAS
6	140	9,22	1.330	45°/ redonda

*Los pesos y medidas son valores orientativos.



Disponible en:



Medidas

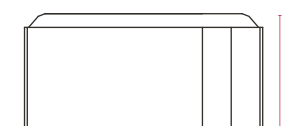
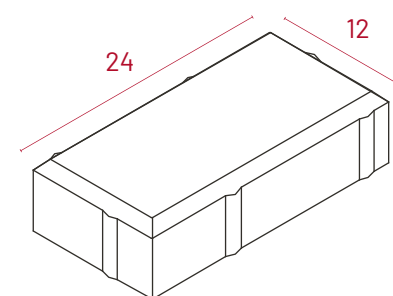

Colores disponibles



Gris Rojo Negro



Crema Tostado Blanco

Propiedades del producto



Hidrofugado



Bicapa



Sostenible



Ecológico





ECOLife® aqua

BALDOSAS

Los beneficios del uso de baldosas de hormigón de Prefabricados Duero incluyen su alta resistencia, durabilidad y facilidad de mantenimiento. Además, estas baldosas son resistentes al deslizamiento y ofrecen una excelente tracción en superficies mojadas, lo que las hace ideales para áreas al aire libre, como patios, piscinas, terrazas y caminos de jardín.

Baldosas | aqua

20x20 ALISTE

Especificaciones técnicas.

Fabricados conforme a la norma **UNE-EN 1339**.

ESPESOR (h)	KG/M ²	M ² /PALET	KG/PALET	ARISTAS
6	140	10	1.400	45°
8	180	10	1.850	45°/ 90°

*Los pesos y medidas son valores orientativos.



Medidas

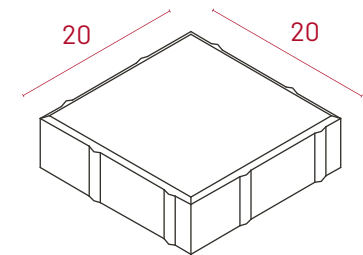

Colores disponibles



Gris Rojo Negro



Crema Tostado Blanco

Propiedades del producto



Hidrofugado



Bicapa



Sostenible



Ecológico

Disponible en:





50x33 CELOSÍA DE CÉSPED

Especificaciones técnicas.

Fabricados conforme a la norma **UNE-EN 1339**.

ESPESOR (h)	KG/M ²	M ² /PALET	KG/PALET	ARISTAS
10	150	6	910	45°

*Los pesos y medidas son valores orientativos.



Medidas

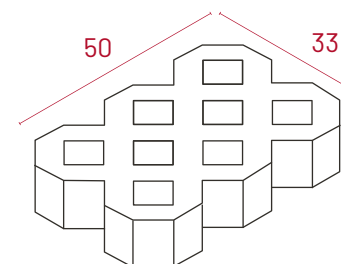

Colores disponibles



Gris

Propiedades del producto



Hidrofugado



Ecológico



Sostenible

Disponible en:







Gama Fusión

GlobalEPD
A VERIFIED ENVIRONMENTAL DECLARATION



fusión®

Colores únicos, para espacios exclusivos
llenos de personalidad y estilo propio

La gama de atractivos colores, exclusivos de Prefabricados Duero,
que imitan la calidez de las vetas naturales y que permanecen
inalterados con el paso del tiempo



fusión®

La **gama fusión®** ofrece pavimentos con una mezcla de colores que proporciona un resultado similar a las vetas naturales, brindando un aspecto cálido y acogedor al entorno

El acabado fusión® es una técnica única que consiste en mezclar dos o tres colores en una sola pieza.

Cada unidad de pavimentación es creada de manera aleatoria, lo que hace que cada pieza sea única y exclusiva.

Además de su belleza natural, los pavimentos de la gama fusión® ofrecen una gran durabilidad, resistencia y facilidad de mantenimiento.

El material utilizado es de alta calidad y diseñado para soportar las condiciones climáticas más extremas y el tránsito diario.



Gama de colores fusión®

Colores únicos, para espacios exclusivos llenos de personalidad y estilo propio

La gama de atractivos colores, exclusivos de Prefabricados Duero,
que imitan la calidez de las vetas naturales y que permanecen inalterados con el paso del tiempo



Altair



Júpiter



Leonis



Mars



Mercury



Mizar



Moon

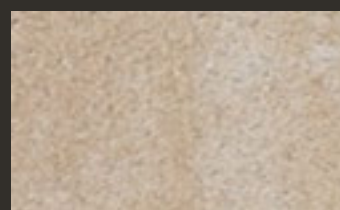

Plutón

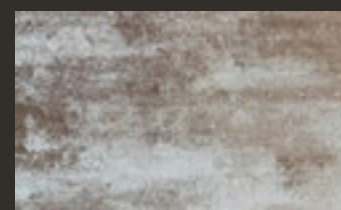

Saturno



Venus



Gama de colores fusión®

ADOQUINES

Los adoquines de hormigón de Prefabricados Duero destacan por su resistencia a la abrasión y al desgaste, así como por su gran estabilidad, lo que los hace ideales para su uso en espacios exteriores con alto tráfico, como calles, plazas, parques y áreas públicas en general.

Adoquines



20x10 TORO

Especificaciones técnicas.

Fabricados conforme a la norma **UNE-EN 1338**.

ESPESOR (h)	KG/M ²	M ² /PALET	KG/PALET	ARISTAS
6	140	10	1.400	90°
8	180	10	1.800	90°
10	220	7	1.585	90°

*Los pesos y medidas son valores orientativos.



Medidas

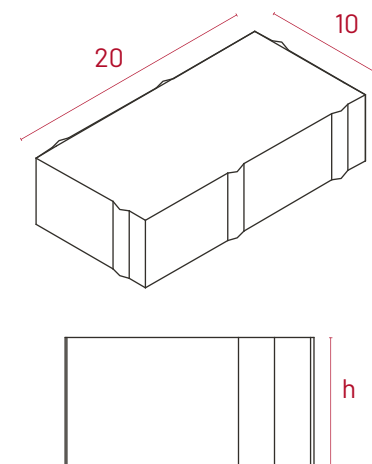

Gama de colores Fusión®

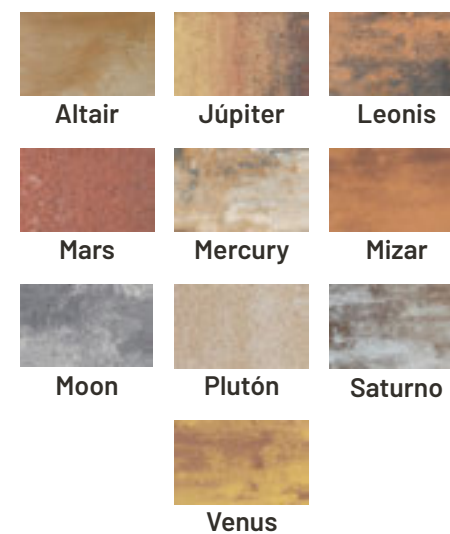

Propiedades del producto



Hidrofugado



Bicapa



Sostenible



Ecológico

Disponible en:





Adoquines



18-12-9x12

CASTELLANO

Especificaciones técnicas.

Fabricados conforme a la norma **UNE-EN 1338**.

ESPESOR (h)	KG/M ²	M ² /PALET	KG/PALET	ARISTAS
8	180	10	1.800	90°

*Los pesos y medidas son valores orientativos.



Medidas

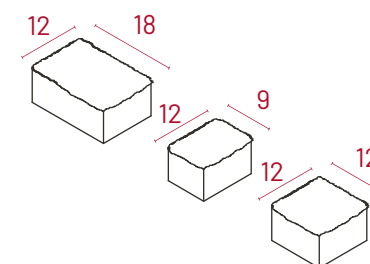

Gama de colores Fusión®

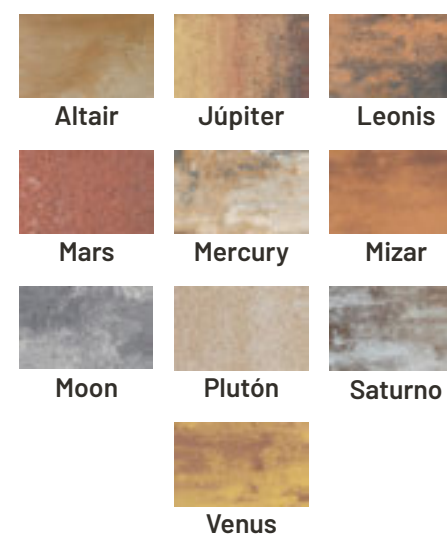

Propiedades del producto



Hidrofugado



Bicapa



Sostenible



Ecológico

Disponible en:







Gama de colores fusión®

BALDOSAS

Los beneficios del uso de baldosas de hormigón de Prefabricados Duero incluyen su alta resistencia, durabilidad y facilidad de mantenimiento. Además, estas baldosas son resistentes al deslizamiento y ofrecen una excelente tracción en superficies mojadas, lo que las hace ideales para áreas al aire libre, como patios, piscinas, terrazas y caminos de jardín.

Baldosas | fusión®

20x20 ALISTE

Especificaciones técnicas.

Fabricados conforme a la norma **UNE-EN 1339**.

ESPESOR (h)	KG/M ²	M ² /PALET	KG/PALET	ARISTAS
8	180	10	1.850	90°

*Los pesos y medidas son valores orientativos.

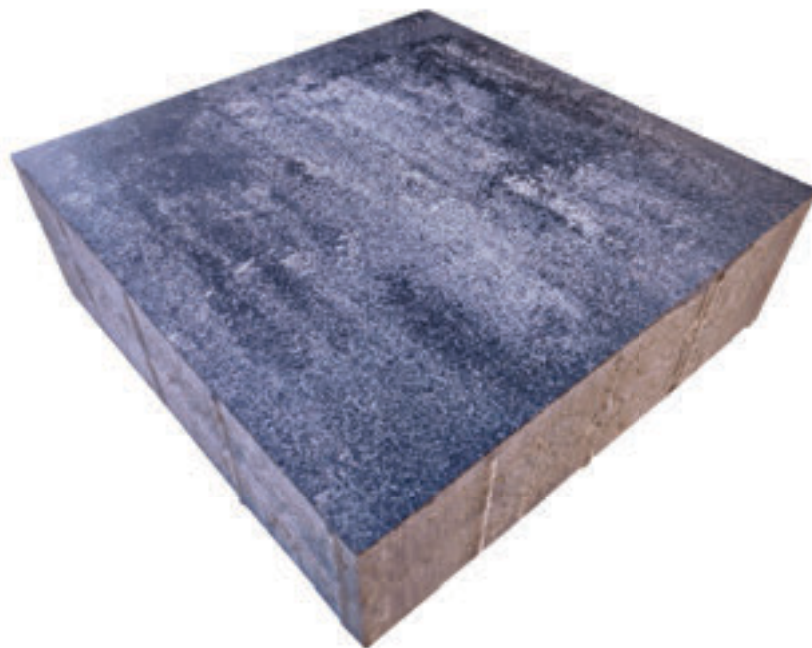

Medidas

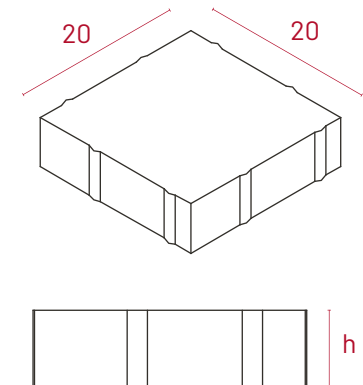

Gama de colores Fusión®

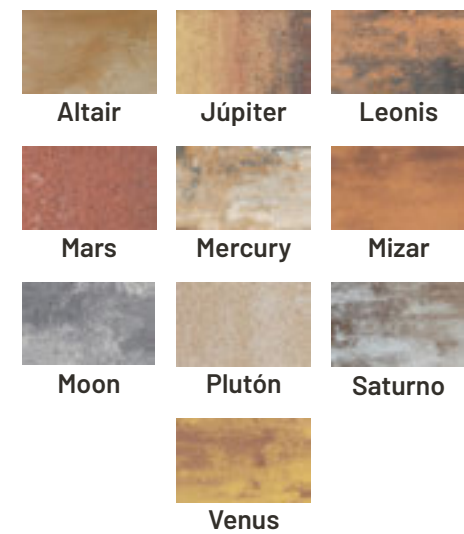

Propiedades del producto



Hidrofugado



Bicapa



Sostenible



Ecológico

Disponible en:





Baldosas



40x20

COLEGIATA

Especificaciones técnicas.

Fabricados conforme a la norma **UNE-EN 1339**.

ESPESOR (h)	KG/M ²	M ² /PALET	KG/PALET	ARISTAS
6	140	9,6	1.400	90°
8	180	9,6	1.750	90°

*Los pesos y medidas son valores orientativos.



Medidas

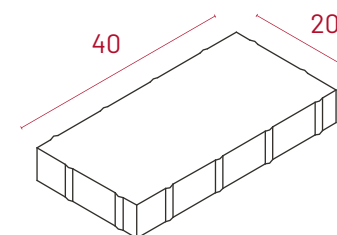

Gama de colores Fusión®

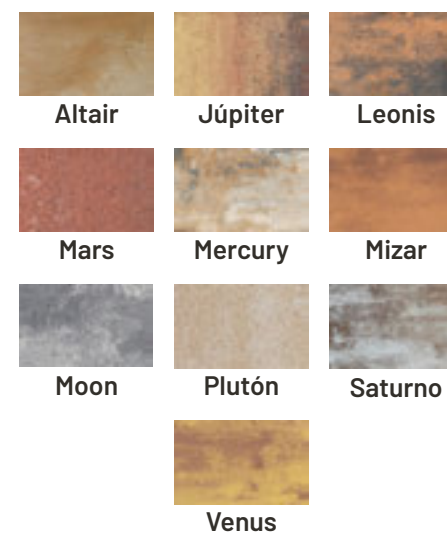

Propiedades del producto



Hidrofugado



Bicapa



Sostenible



Ecológico

Disponible en:



Baldosas



40x40

SAYAGO

Especificaciones técnicas.

Fabricados conforme a la norma **UNE-EN 1339**.

ESPESOR (h)	KG/M ²	M ² /PALET	KG/PALET	ARISTAS
6	140	9,6	1.370	90°

*Los pesos y medidas son valores orientativos.



Medidas

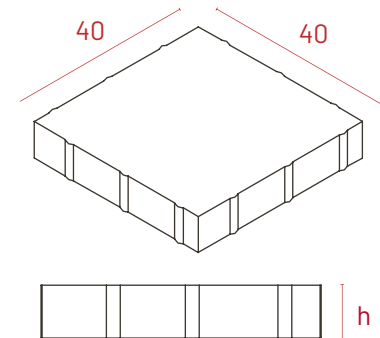

Gama de colores Fusión®

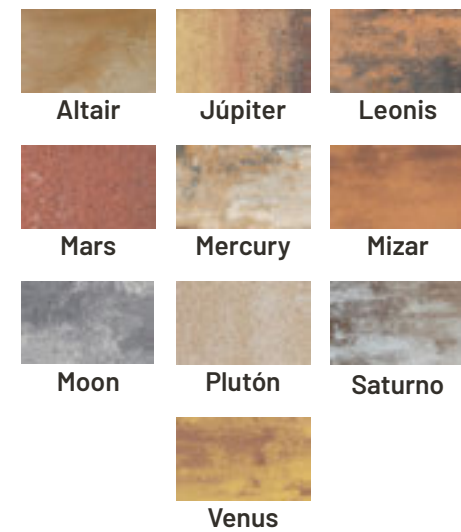

Propiedades del producto



Hidrofugado



Bicapa



Sostenible



Ecológico

Disponible en:





Baldosas



50x50

TERA

Especificaciones técnicas.

Fabricados conforme a la norma **UNE-EN 1339**.

ESPESOR (h)	KG/M ²	M ² /PALET	KG/PALET	ARISTAS
6	140	10	1.420	90°
8	180	10	1.850	90°

*Los pesos y medidas son valores orientativos.



Disponible en:



Medidas

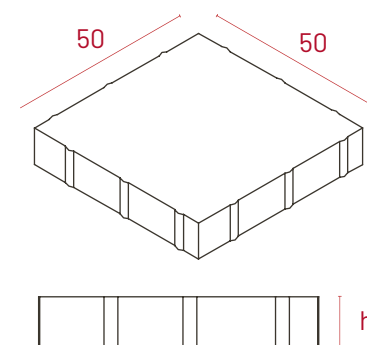

Gama de colores Fusión®

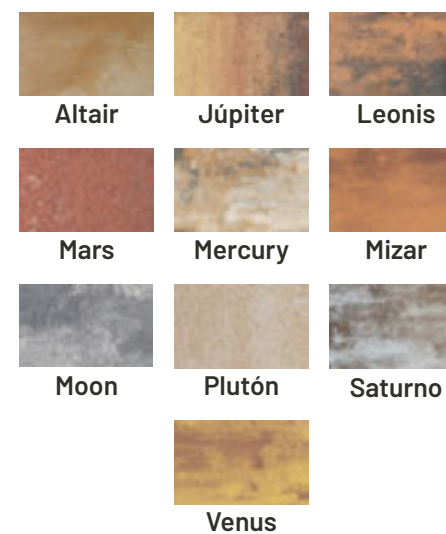

Propiedades del producto



Hidrofugado



Bicapa



Sostenible



Ecológico

Baldosas | fusión®

60x40 | **SANABRIA**

Especificaciones técnicas.

Fabricados conforme a la norma **UNE-EN 1339**.

ESPESOR (h)	KG/M ²	M ² /PALET	KG/PALET	ARISTAS
6	140	11,52	1.630	90°
8	180	10,08	1.850	90°

*Los pesos y medidas son valores orientativos.



Medidas

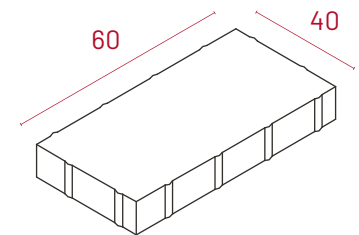

Gama de colores Fusión®

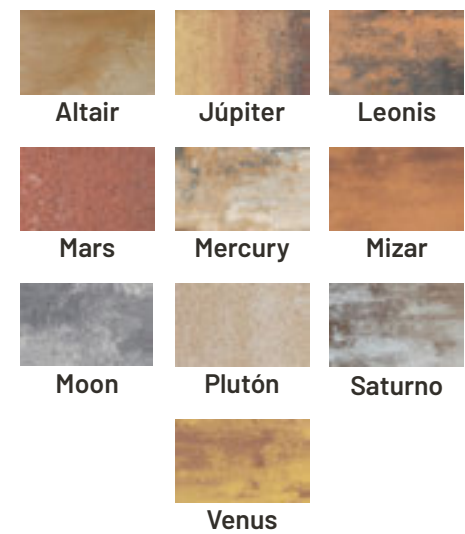

Propiedades del producto



Hidrofugado



Bicapa



Sostenible



Ecológico

Disponible en:





fusión®





Prefabricados Duero

Ctra. Pozoantiguo, Km. 1, 1, 49800 Toro, Zamora

www.prefabricadosduero.com